



Mobile Fly Wire™ Owner's Manual

(previously known as Zippin Zone)



Extreme Engineering
3125 Penryn Road
Suite 330
Penryn, CA 95663
USA

Voice: 916-663-1560
Fax: 916-660-9127
e-mail: info@extremeengineering.com
Website: www.extremeengineering.com

Revision 1.47
July 2014

© 1995 - 2014 Extreme Engineering®

All Rights Reserved

This manual is the property of Extreme Engineering®. Any duplication without Extreme Engineering® written consent is illegal. If you have any questions about the manual, please contact Extreme Engineering.

**THANK YOU FOR PURCHASING AN EXTREME ENGINEERING® PRODUCT, THE BEST
ZIPLINES ON THE MARKET!**

Extreme Engineering® is a U.S. registered trademark of Extreme Engineering®.

US PAT# 6,083,142, 6,390,952, 6,659,496, 7,182,695 and patents pending

US Patents and Patents Pending. Extreme Auto-belay™, Belay in the Box™, PowerBelay™, Space Saver™, C.A.T.T.™, Monkey Motion™, Extreme Air™, Fly Wire™ Auto-Zip™, Fun is our Business™, Flex Pole Technology™, High-Action Adventures™, Decelinator™, Angel Auto-belay™, Speed Harness™, Quad Pod™ and Extreme Air™ are trademarks of Extreme Engineering®. Other trademarks and patents not listed. For a full list of patent and trademark information please contact Extreme Engineering®.



BEFORE YOU START



CAUTION: DO NOT OPERATE THE FLY WIRE™ WITHOUT BEING FACTORY TRAINED BY AN AUTHORIZED EXTREME ENGINEERING TECHNICIAN FIRST. IF YOU FAIL TO DO SO, YOU WILL ASSUME ALL RISK AND LIABILITY AND HOLD EXTREME ENGINEERING HARMLESS FROM ANY INJURIES AND/OR DEATH DUE TO LACK OF KNOWLEDGE, TRAINING AND/OR SERVICE OF YOUR FLY WIRE™ PRODUCT(S).

BY AGREEING TO THE FACTORY TRAINING AND OWNING A FLY WIRE™ ZIPLINE, YOU WILL REPLACE ALL ZIPLINE CORDS AND ADDITIONAL CONSUMABLES AND/OR REPLACEMENT FLY WIRE™ PARTS WITH EXTREME ENGINEERING OEM EQUIPMENT ONLY.

Congratulations!

Congratulations on your purchase of an Extreme Engineering mobile Fly Wire™, winner of Best Major Theme Park Ride at IAAPA. Your mobile zipline has been designed and engineered by the company that invented and innovated numerous recreational equipment products including: mobile and stationary climbing walls, the Belay in the Box™ Auto-belay safety climbing system, Extreme Air™ and Monkey Motion™ jumper systems, Spider Climbs, the Power Belay™ safety rappelling system and numerous other adventure products.

Your mobile zipline is the best in the industry!



Standard mobile Fly Wire™ Zipline model shown in photos above.

Extreme Engineering's® mobile ziplines are designed with safety, ease of operation and durability built in. It will provide you with years of service and the most thrilling mobile zipline experience in the world!

Your mobile zipline is easy to tow, set up, operate and take down. If you follow these instructions carefully and completely, you'll be assured of safe and reliable operation.



Be sure to read and follow all safety instructions found in this manual before operation.

You **MUST ONLY** replace Fly Wire™ parts and/or accessories with OEM, Extreme Engineering components and abide by all maintenance and safety procedures in this manual. If you fail to comply with the maintenance and safety procedures in this manual, you will assume all risk and hold Extreme Engineering harmless from any potential injuries and/or death. Failure to do so will void your warranty and cause severe issues with your Fly Wire™ product.

By owning this product you abide by following all safety and maintenance procedures stated in this manual by Extreme Engineering. This manual is subject to changes, modifications and/or additional procedures stated only by Extreme Engineering. Extreme Engineering has the right to change or update any safety and/or maintenance procedures that may be needed on the Fly Wire™ products. **YOU MUST FOLLOW ALL SAFETY PROCEDURES STATED BY EXTREME ENGINEERING.** You assume all risk and hold Extreme Engineering harmless if you fail to follow Extreme Engineering's safety and maintenance procedures.

We also provide a supplemental training DVD available for purchase. Contact our parts department at 916-663-1560 for details.



Version Update Information

- 1.0 01/30/12 - Original
- 1.1 05/16/12 – Updated Decelinator™ setup procedures, inflatable slide setup, harness and zipline pulley installation, auto-locking door outline and operational procedures.
- 1.2 5/24/12 – Updated trailer specification details.
- 1.3 6/18/12 – Updated safety setup and tear-down procedures, grammatical errors and updated illustrations.
- 1.4 7/10/12 – Grammatical changes and clarification to manual and illustrations.
- 1.41 7/25/12 – Table of contents added. Emergency evacuation clarified. Additional clarification on zip cords and maintenance schedule included. Additional clarification on lanyard adjustments included. Additional remarks on allowing 2 zipliners at the same time at 250 lbs each is included. Safety sticker outline for both trailer and Decelinator™ is included.
- 1.42 9/6/2012 – Shims reference has been removed from page 51.
- 1.43 10/04/2012
- 1.44 8/30/2013 – Clarified use limit on cables, clarified inspection procedure on cables.
- 1.45 10/31/2013 – Updated Table of Contents, edited formatting, optional inflatable slide is not for use in New Jersey.
- 1.46 2/4/2014 - Per the state of New Jersey state requests. Updates have been added to section 1.1 of the Safety Rules on page 7 to include horizontal requirements in reference to NFPA.
- 1.47 7/18/14 – Includes warning on caution notices to prevent hitting the winch handles into “free-spool” mode. Company logo change and updated product photo added to front page of manual. Updated Fly Wire Renderings added to the “DO NOT operate” portion of the manual.



Table of Contents

Topic	Page(s)
1.1. Safety Rules	7-10
2.0. Pre-Travel Check List	11-12
2.1. Tow Vehicle Safety Check	11
2.2. Mobile Fly Wire™ Safety Check	12
3.0. Prepare for Towing	13-27
3.1. Attach Fly Wire™ To Tow Vehicle	13-17
3.2. Pre-Travel Safety Inspection Details	17-27
4.0. Mobile Fly Wire™ Setup	27-80
4.1. Position the Mobile Fly Wire™	27-28
4.2. Offloading the Decelinator™ From the Trailer	28-33
4.3. Attaching Zip Cords to Fly Wire™ Tower	34-43
4.4. Unhitch Tow Vehicle	43-45
4.5. Prepare the Fly Wire™ For Raising	46-50
4.6. Raise the Fly Wire™ Tower	50-55
4.7. Inflatable Slide Setup (optional)	56-60
4.8. Applying counterweight to the Decelinator™	61-63
Counterweight Diagram	63
4.9. Setting Tension on Decelinator™	64-70
4.10. Plugging in safety box/auto-locking door controller from the Fly Wire™ platform to the Decelinator™	71-72
4.11. Test Zipline / Harness installation	73-79
5.0. Prepare To Operate the Fly Wire™	79-80
6.0. Banner Options	80
7.0. Harness/Zipline Pulley setup instructions	81-83
8.0. Operating the Fly Wire™	84-93
8.1. Operating techniques /Diagrams	84-89
Emergency Evacuation Plan Diagram	88
8.2. Safety Rules For the Operator	89
8.3. Safety Rules For Zipliners/Safety Sign Template	91
8.4. Special Zipline Situations	92-93
9.0. End of Event Takedown	93-111
9.1. Lower the Decelinator™	93-103
9.2. Prepare the Fly Wire™ For Transport and the Decelinator™ For Loading	104-111
10.0. Troubleshooting	111-112
11.0. Frequently Asked Questions	113-115
12.0. Maintenance	115-120
13.0. Replacing Zip Cord Assembly	121-122
13.1. Remove the old zip cord assembly	121
13.2. Replace the new zip cords	121-122
13.3. Test the new zip cords on the Fly Wire™	122
14.0. Replacing Cable on Loading/Offloading Fly Wire™ Winch	122
14.1. Remove the Old Cable From the Fly Wire™ Winch	122
15.0. Cleaning and Other Special Care	123-128
15.1. Protection From the Elements	124
15.2. Quick Checklists and Log	124
15.3. Pre-Use Maintenance Checklist	124-126
15.4. Periodic Maintenance Checklist	126-127
15.5. Maintenance Log Template	128
16.0. Safe Towing Tips	129
17.0. Specifications	130-131
17.1. Fly Wire™ Trailer Specifications	130
17.2. Mobile Fly Wire™ Lift Pump Specifications	131
17.3. Decelinator™ Specifications	131
17.4. Trailer Winch	131
18.0. Wiring Diagrams / Battery Maintenance	132-140
18.1. Marine Deep Cycle Battery Required	136-137
18.2. Battery Operation	137-138
18.3. Battery Charging	138
18.4. What is and Why Use a "Smart Charger"	138-140
19.0. Product Safety Sticker Outline	140-142
19.1. Fly Wire™ Trailer Safety Sticker Outline	140-141
19.2. Decelinator™ Sticker Outline	142
20.0. Limited Warranty	143-145
21.0. Warranty Claim	145-146
22.0. Replacement Parts	146
23.0. Technical Support	146
Warranty Claim Form	147



1. Safety first! Read Before Proceeding



CAUTION: This is a safety alert symbol. It is used to alert you of potential personal safety hazards. Please read all safety messages that follow this symbol to avoid injury or death.

Always make safety your number one priority when setting up, operating and taking down your mobile Fly Wire™.



CAUTION: You MUST ONLY use Extreme Engineering's zip cords when replacing your zipline cords for safe operation. Failure to use Extreme Engineering zip cords can result in serious injury or death! DO NOT use non-Extreme Engineering rope, cable and/or cords on a Fly Wire™ zipline. You assume all risk and hold Extreme Engineering harmless from any injuries and/or death by failing to comply to the safety and replacement procedures of this manual.

1.1. Safety Rules



CAUTION: For your safety, read and follow all safety rules and safety instructions in this owner's manual before operating your mobile Fly Wire™.



CAUTION: **DO NOT** set up or operate the mobile Fly Wire™ near overhead electrical lines, roof eaves, trees, or other overhead obstructions or hazards. Please look up and around the Fly Wire™ before raising the product.



CAUTION: Fly Wire™ should never be operated within 15 feet horizontally from overhead conductors, in compliance with NFPA 70 Article 525.5 B (1) & (2).





CAUTION: DO NOT set up or operate the mobile Fly Wire™ in windy conditions where wind gusts exceed 25 MPH. Should wind gusts appear after setting up the mobile Fly Wire™, stop operating the mobile zipline and lower the mobile zipline tower immediately with caution.



CAUTION: DO NOT set up the mobile Fly Wire™ on uneven and/or non-level surfaces. The maximum slope allowed for setup and operation of the mobile Fly Wire™ is 3%. Within this 3% maximum slope, you can further level the Fly Wire™ with shims if necessary.



CAUTION: DO NOT set up the mobile Fly Wire™ if there is extremely bad weather such as lightning, thunderstorms, rain, tornados, hail, etc. Always ensure the weather forecast is acceptable before every event.



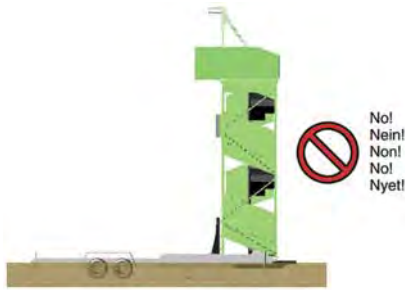

CAUTION: Set up the mobile Fly Wire™ only on firm, hard packed, surfaces such as concrete, pavement, hard packed dirt, etc. **DO NOT** set up the Fly Wire™ on soft or loose ground or other unstable surfaces.



CAUTION: Extreme Engineering advises to not operate the Fly Wire™ in low lighting conditions or at night. If you choose to operate during low lighting conditions and/or at night, please ensure that the product is well lit to minimize any tripping hazards.



Extend the jacks down onto firm, hard packed surfaces only. **DO NOT** use blocks under the jacks. **DO NOT** lower the jacks onto soft ground, sand or other unstable surfaces.



CAUTION: Extreme Engineering highly recommends a second operator to help with setup. This second operator can look for (and provide warning on) potential issues or hazards that may not be seen by a single operator. If your Fly Wire™ is equipped with the optional slide two operators are needed to safely set up the slide.



CAUTION: Keep the area clear of people, cars, etc. during setup. **DO NOT** walk under, nor allow anyone to walk or crawl under the tower portion of the mobile Fly Wire™ while it is being raised up to the operating position or being lowered down to the travel position.





CAUTION: DO NOT allow anyone to climb and/or crawl on the outside of the Fly Wire™.



CAUTION: DO NOT climb onto, sit or stand on the top of the Fly Wire™.



CAUTION: DO NOT use the zipline without being properly connected by a trained operator. Never use the Fly Wire™ without being harnessed, connected to the zipline pulley, cord and with the Decelinator™ properly engaged. All zipliners must wear an Extreme Engineering Zipline harness and be securely fastened to the zipline cord with an approved Extreme Engineering carabiner and Extreme Engineering Zipline pulley. No one should ride the Fly Wire™ without an operator at the top of the platform securing the participant safely to the zipline.

UNAUTHROIZED patrons are strictly prohibited from walking up the staircase and to the top platform without an operator present.



CAUTION: Inspect the mobile Fly Wire™ before each day's use.

The maintenance section of this owner's manual includes comprehensive details for making a complete inspection. Read that section carefully.

If you find any problems during the inspection which you cannot resolve, DO NOT operate the zipline until the problem is corrected.

Visit Extreme Engineering's technical support web page at <http://www.extremeengineering.com/about-us/technical-support/> or contact Extreme Engineering's Technical Support at 916-663-1560 for help in correcting any problems.



2. Pre-Travel Checklist



CAUTION: For your safety, read all instructions before towing the mobile Fly Wire™.

2.1. Tow Vehicle Safety Check

- ✓ Check the air pressure in all tires including spare tire. Check for tire damage and ensure tread depths are sufficient on all tires.
- ✓ Check fuel and oil levels.
- ✓ Check dash gauges and warning lights on with key turned to “on position” without engine running and with engine running.
- ✓ Check that all promotional items, lights and displays are secure and travel ready. **DO NOT** use the Fly Wire™ trailer as a hauling trailer. You should only store Fly Wire™ related components with the trailer.
- ✓ Check that all promotional items, lights and displays are not stacked on top of the Fly Wire™ product.
- ✓ Check the towing hitch and towing ball for proper attachment and tightness on towing vehicle per towing hitch manufacturer’s specifications
- ✓ Check towing ball for proper size (2 5/16”) and for abnormal wear.
- ✓ Ensure the weight limits of the tow vehicle’s towing hitch are greater than the total load weight and tongue weight of the mobile Fly Wire™.
- ✓ Ensure that the towing capacity of the tow vehicle can safely tow the weight of the Fly Wire™. Refer to the vehicle’s towing specifications for details.



2.2. Mobile Fly Wire™ Safety Check

- ✓ Check towing coupler mounting bolts for proper tightness.
- ✓ Check coupler for damage or unusual wear.
- ✓ Check tow tongue mounting bolts for proper tightness.
- ✓ Check all tires (including spare tire, if equipped) for proper air pressure.
- ✓ Check tires for legal tread wear depth.
- ✓ Check wheel lug nuts for proper tightness or if missing.
- ✓ Check Fly Wire™ and Decelinator™ lift pump for proper fluid level. Both pumps use ATF (automatic transmission fluid) Dextron III/Mercon.
- ✓ Check for oil leaks from all hydraulic hoses and fittings from the lift pumps (Fly Wire™ and Decelinator™) to the hydraulic lift rams. Note: There may be oil residue found at the fill cap area of the lift pump oil reservoir tank. The fill cap is a breather cap and may allow a small amount of oil to escape from the tank during travel.
- ✓ Check for grease in the main hinge pins where the upper tower attaches to the lower trailer base at the rear.
- ✓ Check the Decelinator's™ coil springs for any cracks, fatigue and/or severe wear.
- ✓ Check Extreme Engineering's zipline cords for cuts, tears, broken strands and/or signs of wear.
- ✓ Check both lift pump batteries for sufficient levels of charge.
- ✓ Do a walking inspection around the trailer, Decelinator™, zipline tower, optional slide and other moving parts.
- ✓ Look for and remove any debris attached to the under body of the trailer.
- ✓ Check that the trailer position is horizontal and level for travel.
- ✓ Remove wheel blocks for departure.



3. Prepare For Towing



CAUTION: For your safety, read all instructions before attaching the Fly Wire™ to the tow vehicle.

Extreme Engineering recommends a solid tow vehicle hitch receiver for towing the mobile Fly Wire™. Ensure the solid receiver is properly inserted and attached per the towing hitch manufacturer's specifications and requirements. Check the towing hitch and towing ball for proper attachment and tightness on the towing vehicle per towing hitch manufacturer's specifications.

Ensure vehicle towing capacity and the towing hitch limits are greater than the total weight and tongue weight of the Fly Wire™.

Check towing ball for proper size and for abnormal wear.



CAUTION: DO NOT tow the zipline without the proper size towing ball. The ball must be 2 5/16" diameter. A smaller ball can allow the trailer to unhitch, even with the coupler locking latch and safety pin in place. Do not change and/or modify the hitch size from 2 5/16". Modification will void the warranty and cause serious damages to your Fly Wire™. **DO NOT** modify the trailer in any way. Modification of the trailer can be catastrophic. The trailer tongue is welded onto the frame and does not require tightening. No torque wrench is required.

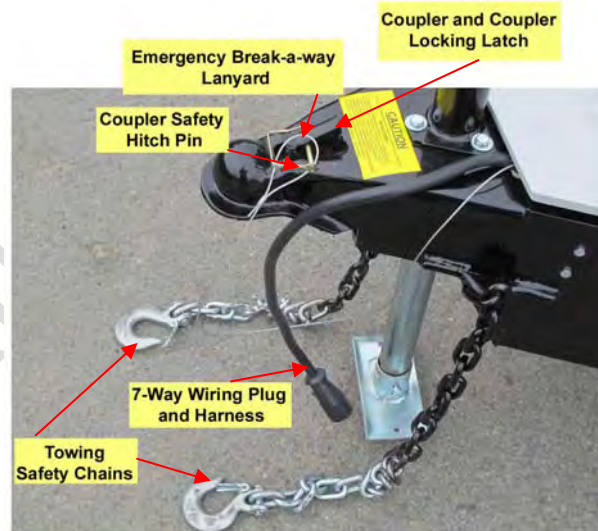

Fly Wire™ and tow vehicle towing components



3.1. Attach Fly Wire™ To Tow Vehicle

Back the tow vehicle into position so that its towing ball is under the mobile Fly Wire's™ trailer tongue. If you have a second operator, have the operator stand by the trailer to guide you into position. Position the tow vehicle's hitch as close as possible to the tongue of the trailer with the trailer coupler as close to directly above the towing ball as possible.



CAUTION: Avoid manually positioning the trailer! **DO NOT** attempt to pull the trailer by hand, as this could result in serious bodily injury. If you need to adjust the trailer onto the towing vehicle, restart the backup process.



Lower the coupler down onto the tow ball once the tow vehicle is properly aligned with the trailer's coupler. Using the front jack mounted to the tongue, turn the jack handle counter clockwise until the coupler is fully engaged over the tow ball. Continue to turn the jack handle until the foot of the jack is clear off the ground and in the travel position.

Lower the coupler latch handle to the fully down position. **Ensure the latch handle safety lock inserts into its locking slot** on the coupler body underneath the latch handle. If the latch is in its proper position, you should not be able to lift the latch handle without first releasing the latch handle safety lock lever. Make sure to visually inspect that the coupler is locked down on the towing ball by looking underneath the tow hitch.





CAUTION: DO NOT tow the mobile Fly Wire™ without the latch handle in the locked position.

Locate the **safety hitch pin** through the hole on the side of the coupler where the coupler latch handle mounts to the coupler body. **Slide the safety hitch pin clip over the pin** of the safety hitch pin to prevent the coupler latch handle from being accidentally released.

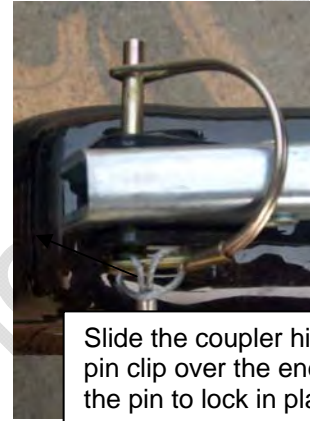

Slide the coupler hitch pin clip over the end of the pin to lock in place



CAUTION: DO NOT tow the mobile Fly Wire™ without the coupler hitch pin properly set in place on the coupler latch handle.

Attach the two towing safety cables/chains to the tow vehicle's hitch.



NOTE: Image may vary based on which type of towing cables/chains are used on trailer.

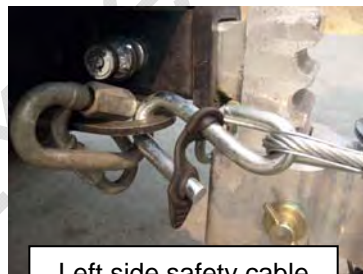

Left side safety cable

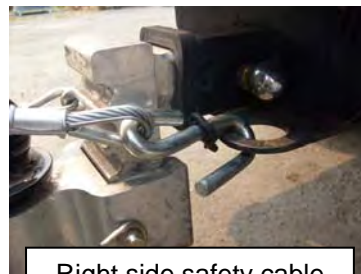

Right side safety cable



CAUTION: DO NOT tow the mobile Fly Wire™ without the safety towing cables properly attached to the towing vehicle. If the safety towing cables are worn or missing **DO NOT** tow the mobile Fly Wire™. Make sure the safety towing cables are present, correctly installed and in good working order.



Attach the electrical plug from the mobile Fly Wire™ to the towing vehicle. The current Fly Wire™ U.S. models use the 7-way, round RV plug (shown in the example below). Ensure the plug is fully inserted into the tow vehicle's electrical socket. Ensure the socket cover safety catch on the 7-way style is firmly in place down over the rear of the plug to prevent the plug from falling out during travel.



Electrical Towing Plug properly inserted into tow vehicle socket with socket cover safety catch down over trailer plug

 **CAUTION: DO NOT** tow the mobile Fly Wire™ without the electrical plug attached to the towing vehicle.

Attach the emergency brake break-away lanyard to the tow vehicle. The lanyard must be attached to the tow vehicle, not the towing safety cable. Ensure the emergency brake break-away switch pull tab is fully inserted into the break-away switch.



Emergency Brake Break-A-Way Lanyard Attachment



Emergency Brake Break-A-Way Pull Tab





CAUTION: DO NOT tow the mobile Fly Wire™ if the emergency brake-away lanyard is missing, or if it is not attached.

Verify operation of tow vehicle and mobile Fly Wire™ lights. The mobile Fly Wire™ tail lights and side/top marker clearance lights should be on when the tow vehicle's parking lights or headlights are on. The mobile Fly Wire™ brake lights operate when the tow vehicle's brake pedal is depressed. Both of the mobile Fly Wire™ brake lights will flash when the tow vehicle's 4-way emergency switch is turned on. The mobile Fly Wire™ left and right turn signals should operate with the respective left and right turn signals of the tow vehicle.



CAUTION: DO NOT tow the mobile Fly Wire™ without operational tail lights, brake lights and turn signal lights.

Perform a secondary visual inspection. Ensure all towing components are properly attached and/or connected prior to towing the mobile Fly Wire™.

3.2. Pre-Travel Safety Inspection Details



Move all jacks to the travel position.



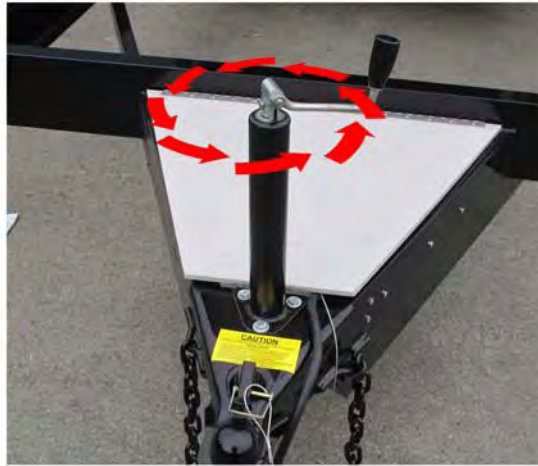

Lower the tongue jack on the towing vehicle by turning the handle counter-clockwise.

For the front trailer base jack located on the tongue, raise the jack off of the ground and into the travel position by turning the handles counter-clockwise. Turn the jack handle counter-clockwise until you can no longer raise the jack's leg off the ground.



1 Locate all four stabilizing jacks.



2 Turn jack handle counter-clockwise to raise the jack leg off the ground.



3 Pull safety lock clip from drop leg pin.



4 Remove drop leg pin from drop leg.



5 Push drop leg up into jack and securely fasten the leg pin back into place.



6 Continue to raise the jack, counter-clockwise, until you no longer can bring up the drop leg.

For the four stabilizing jacks, pull the jack's drop leg pin out, raise drop leg into jack and pin back into place, and raise jack legs off of the ground into the travel position by turning the



handles counter-clockwise.

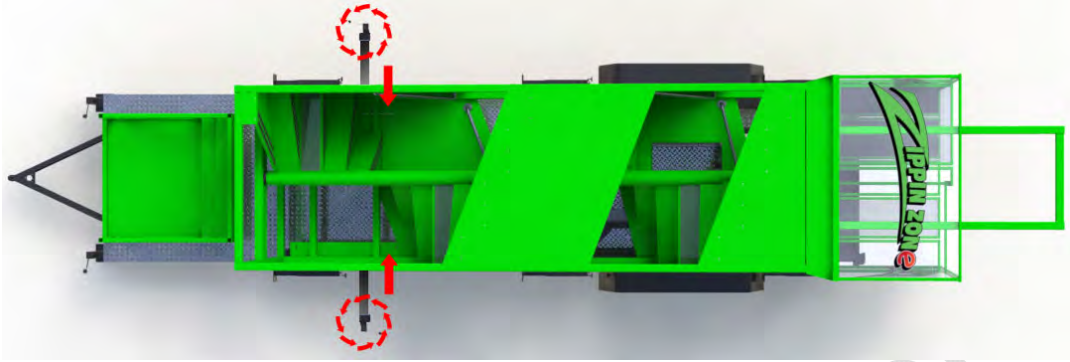

Ensure that the two outrigger jacks are in the towing position and not extended from the trailer.

Setting outriggers into the towing position.



Crank jack handle counter-clockwise and pull release hook to raise drop leg back into the jack.



Ensure that the drop leg locks back into the jack.



Pull up the pop-pin to allow the outrigger to slide back towards the trailer.



Slide the outrigger towards the trailer until the pop-pin locks back into place.

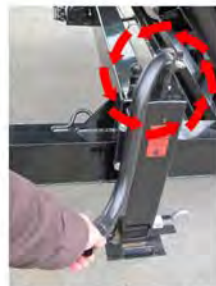

Turn jack handle counter-clockwise until you no longer can raise the jack.



Repeat step on other outrigger if necessary.

Pull the pop-pins up and slide the outriggers in and toward the trailer base. Raise the jack legs by turning the handles counter-clockwise. Ensure that the drop leg is fully raised into the jack.



CAUTION: DO NOT tow the mobile Fly Wire™ with any jack deployed and not in the travel position. Jacks can also be removed and stored in either the toolbox (optional



equipment) on the mobile Fly Wire™ or in the tow vehicle during transport. Make sure that no jacks are missing on the Fly Wire™ product.

Inspect all wheel lug nuts, tire pressures and tread depths, hub dust caps and suspension.

The wheel lug nuts are to be torqued to 90 ft-lbs (foot pounds).

For factory supplied tires, the tire air pressure should be 80 psi with a cold tire. If you no longer have factory tires or exact factory replacement tires, use the recommended tire pressure imprinted on the side of the tire for proper inflation requirements. Any local tire shop can help if you are not sure what the tire air pressure should be on your tire.

Check that all tire tread depths are equal to or exceeding requirements. There are tire wear tread indicators in place on all tires in various areas around the circumference of the tire between the tire treads. If these tire wear indicators are at the same height as the tread, the tires must be replaced.

Ensure all the hub dust caps are in place on all axles.

Check all mounting points of the suspension. Check to ensure the spring mounting shackles/bolts and u-bolts are in place and tight.

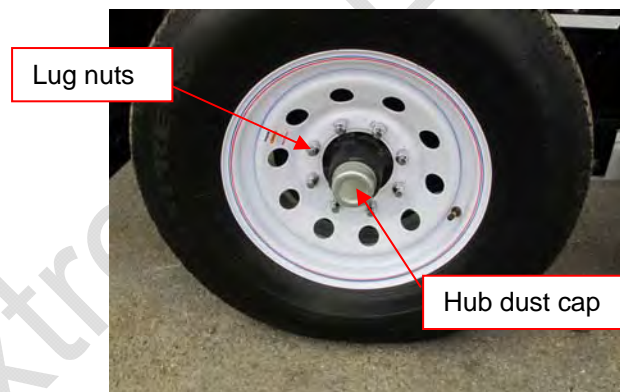

CAUTION: DO NOT tow the mobile Fly Wire™ with missing/loose lug nuts, improper tire air pressure, missing hub dust caps or missing/loose spring mount components or without required minimum tire tread depths.

Inspect fenders, toolboxes (optional) and spare tire (optional).

Check the toolbox (optional equipment) mounting points. Ensure that the toolbox is securely fastened to the Fly Wire™ trailer, the toolbox lids properly open/close and the locks are in working order.



The spare tire (optional equipment) is mounted on the trailer. Ensure that the spare tire mounting bracket is securely fastened to the trailer. Check that the spare tire is fastened to the mounting bracket. The spare may be mounted in different locations depending on which optional equipment is installed.

For bolt-on style fenders, check to ensure the mounting hardware is securely fastened to the fenders and the trailer base.



CAUTION: DO NOT tow the mobile Fly Wire™ with non-secured or improperly mounted fenders, toolboxes and/or spare tire. Towing the mobile Fly Wire™ with non-secured or improperly mounted fenders, toolboxes and/or spare tire can be catastrophic when towing and can cause severe damage to the Fly Wire™.

Inspect battery boxes and hydraulic pumps/hoses/lift rams

There are three batteries on the zipline. One battery box is mounted to the main trailer base pan with pop-rivets, and the other battery boxes are located on the Decelinator™. Ensure that all pop-rivets are securely in place and the battery boxes are tight with the batteries correctly fastened to the product.

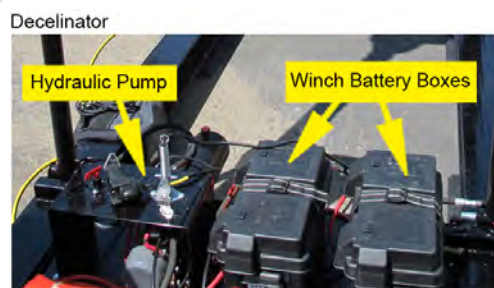

There are two hydraulic pumps on a Fly Wire™ system. One pump is mounted to the main trailer base pan with bolts. The other pump is located on the Fly Wire's™ Decelinator™. Ensure that both the Fly Wire™ and Decelinator™ pumps are securely fastened with bolts.



The bolts are located underneath the base pan on the Fly Wire™ and on the mounting bracket of the Decelinator™. Ensure the bolts are securely tightened in place.

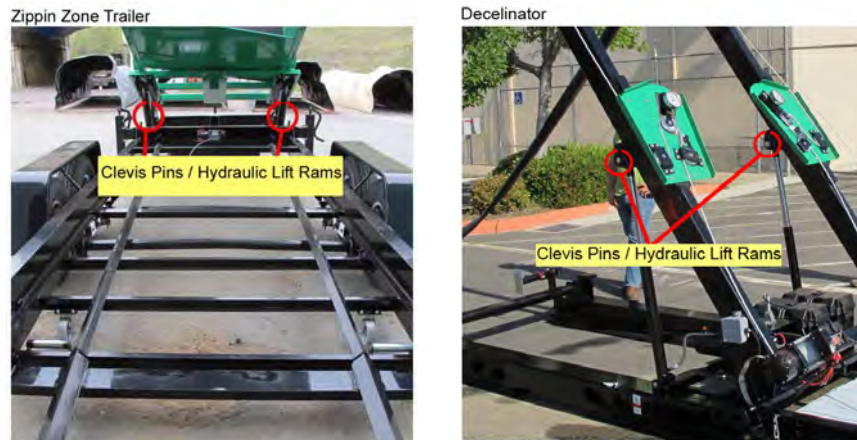

The hydraulic lift rams are mounted to the base frame and the zipline tower frame with clevis pins at each end. There is an external retaining ring on each outside end of the clevis pins holding the lift rams in place. There are also two lift rams on the mobile Fly Wire's™ Decelinator™.

Check for leaks at all hydraulic fittings, hose connections and lift rams.

Inspect Decelinator™



Be sure that the Decelinator™ is completely lowered and not preventing the zipline tower from being lowered onto the Fly Wire's™ trailer. The zipline tower should not be touching or resting on the Decelinator™ while in the travel position.



It is imperative that the Decelinator™ is securely fastened to the Fly Wire™ trailer during transport. The trailer base has a track that guides the Decelinator™ into place during transit. Ensure that the Decelinator™ is correctly resting on the track and that the winch is connected to the load hook of the Decelinator™ (see diagram above). Ensure that there is still tension on the winch's cable, no slack, when holding the Decelinator™ on the Fly Wire™ trailer.

Connect the safety chain from the trailer to the Decelinator's™ load hook. This is the same load hook that the winch's cable stays connected to. The safety chain is a backup precaution to prevent the Decelinator™ from movement or securely hold the Decelinator™ in place during transit if the trailer winch's cable fails.



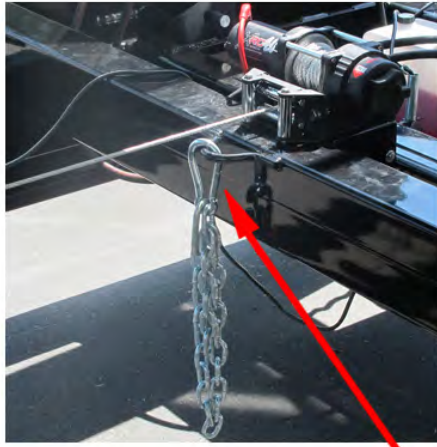

Safety Chain

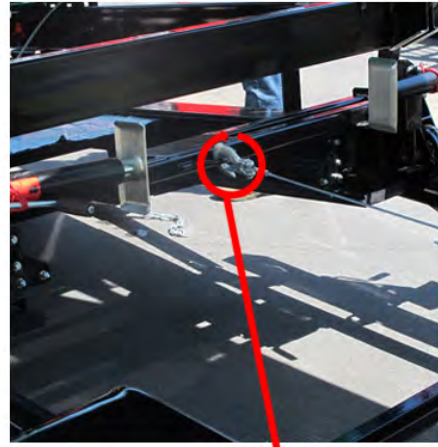

Decelinator Load Hook

The ramps should also be folded upright in the towing position.



Do a visual inspection of the entire Decelinator™. Check the springs for wear, lift rams and pump for oil leaks, hydraulic hoses for leaks, charge and test battery, check battery cables, inspect winches for signs of wear and check the Extreme Engineering zip cords for wear. Check the overall Decelinator™ for any broken or loose parts. Replace or repair loose or broken parts.



CAUTION: NEVER tow the Fly Wire™ without the Decelinator™ securely fastened to the trailer. Towing the Fly Wire™ without the Decelinator™ securely fastened to the trailer can be catastrophic when towing and cause severe damage to the Fly Wire™.



CAUTION: If the Decelinator™ seems suspect, or is damaged **DO NOT** operate the Fly Wire™ product.



CAUTION: DO NOT tow the mobile Fly Wire™ with a non-securely fastened battery box, hydraulic pump and/or lift rams. **DO NOT** operate the zipline if there are leaks in the hydraulic hoses, fittings and/or lift rams.

Ensure the batteries are sufficiently charged. Extreme Engineering recommends the batteries be charged the day before operating at an event to ensure a full charge. The



batteries are a Group 27, deep cycle, marine battery rated for boat trolling motors (refer to the battery maintenance section in the manual. A vehicle battery will not work, as a vehicle battery's intended use is far different from a marine battery's usage. To ensure continual success at raising and lowering both the Fly Wire™ platform and Decelinator™, Extreme Engineering recommends using a "Smart Charger" type of battery charger. This style of charger regulates the charge based upon what it reads from the battery as well as turning itself off when the battery is fully charged. **DO NOT** use a low amp trickle charger that does not turn off on its own. **DO NOT** leave the batteries on charge for extended days as this will significantly shorten the life of the batteries.



NOTE: You can purchase a smart charger at any local hardware shop. Extreme Engineering recommends purchasing the "Black and Decker" smart charger models for charging your battery.

Ensure the hydraulic lift pumps have sufficient oil. Maximum oil fill is when the oil in the tank is at the 2/3 level when the Fly Wire™ platform and Decelinator™ are in the towing position or down. Never let the oil drop below the 1/4 level on the tank when the Fly Wire™ is in the fully upright position. When adding oil, use Dextron III Automatic Transmission Fluid.



CAUTION: DO NOT operate the Fly Wire™ and Decelinator™ with an insufficient oil level in the reservoir tank.



CAUTION: DO NOT use fluids other than Dextron III Automatic Transmission Fluid in the pumps. Using fluids other than Dextron III Automatic Transmission Fluid in the pumps can cause severe damage to the Fly Wire™ and Decelinator™.



CAUTION: DO NOT tow or operate the mobile Fly Wire™ with loose or missing lift arm mounting bolts, washers and/or nylock nuts.



NOTE: Adding too much fluid to the tank will cause an overflow and force fluid out of the pump. To prevent a messy spill, don't overfill the tank.





Periodic greasing of lift ram and base hinge pin zerk fittings. Using a grease gun, apply grease to both fittings of each lift ram and the fitting on each main hinge pin fitting. The fittings should be greased on a monthly basis. Apply grease until you can see new grease extruding from either side of the tubes which the zerk fittings are attached to (see images below).



Upper Ram Grease Fitting



Lower Ram Grease Fitting



Base Hinge Grease Fitting

Inspect the zipline cords, zipline pulleys, pulleys, springs and carabiners for damage.

Ensure the Extreme Engineering zip cords are tightly twisted with no bird-caging. Bird-caging is where all of the individual strands of the cord are untwisting and separating from each other. Ensure there are no broken strands or other damage found anywhere on the cords and/or springs. If any of these conditions are found, the zip cord assembly (includes spring packs) must be replaced with Extreme Engineering's zip cords prior to use.



CAUTION: DO NOT replace the Fly Wire™ cords or springs with aftermarket rope, cable or springs. You MUST use Extreme Engineering's zip cords for proper operation. Failure to use Extreme Engineering zip cords can result in serious injury and/or death. Failure to use Extreme Engineering zip cords will void the product warranty. You assume all risk and hold Extreme Engineering harmless for any injuries and/or death by failing to use cords other than Extreme Engineering's or if you don't replace them annually. Zip cords include spring packs and MUST be replaced annually.

Inspect all zipline pulleys for abnormal wear or damage. If found, replace ONLY with Extreme Engineering zipline pulleys. Inspect the pulleys on the tension plates (located on Decelerator™) for signs of wear. If found, replace ONLY with Extreme Engineering pulleys.



CAUTION: DO NOT use aftermarket zipline pulleys on the Fly Wire™ system. Aftermarket pulleys are not designed for safe use on the Fly Wire's™ cords. Replace zipline pulleys only with Extreme Engineering's zipline pulleys, specifically designed for the Fly Wire's™ zip cords. Failure to use Extreme Engineering zipline pulleys can result in serious injury and/or death. Failure to use Extreme Engineering zipline pulleys will void the product warranty. You assume all risk and hold Extreme Engineering



harmless for any injuries and/or death by failing to use Extreme Engineering's zipline pulleys or if you don't replace them annually.

Inspect all carabiners for abnormal wear or damage and check that the triple locking action of the carabiner clasp is operating properly. If abnormal wear is found, replace the carabiner as soon as possible. If the locking action is not working properly, **DO NOT** use the carabiner. It must be replaced before operating the Fly Wire™.



CAUTION: DO NOT operate the mobile Fly Wire™ with damaged cords, zipline pulleys and/or carabiners. **DO NOT** use cords, zipline pulleys or carabiners with excessive wear. **DO NOT** use any carabiner where the triple action locking mechanism of the clasp does not operate properly on its own without help. **DO NOT** use non-rated carabiners or aluminum carabiners, such as a Petzl® Ball-lock, or other type of screw gate locking carabiners. Please contact Extreme Engineering to order your proper zipline carabiners at 916-663-1560.



NOTE: Ensure that you carry your Fly Wire™ and Decelinator™ lift controllers with the products. Without controllers the product cannot be set up or operate.

4. Mobile Fly Wire™ Setup



CAUTION: For your safety, read all instructions before pulling the tow vehicle away from the mobile Fly Wire™. Prior to positioning the mobile Fly Wire™, read and follow the safety instructions found at the beginning of this manual.

4.1. Position the Mobile Fly Wire™

Using the tow vehicle, **position the mobile Fly Wire™** in the location where the zipline ride will end. Ensure there is an adequate operational area entirely around the mobile Fly Wire™ and overhead for raising, operating and lowering the Fly Wire™ and Decelinator™. Ensure that you are setting up the complete product on level and firm surfaces and the operational area is free and clear from obstructions.

Make sure the landing surface is clean and clear of debris. It might be a good idea to bring a blower and broom in case the surface needs cleaning.



CAUTION: DO NOT set up the Fly Wire™ where the ziplines will be over obstructions and/or crowds.

First, position the Fly Wire™ where the zipline will end and where the Decelinator™ will be located™. Stage the Fly Wire™ for the process of moving the Decelinator™.



NOTE: Do not remove the towing vehicle from the trailer. The towing vehicle will still be needed for pulling the Fly Wire™ forward and away from the Decelinator™.





NOTE: Depending the chosen length of the zipline, ensure the distance is no greater than 220 feet (67.07 meters). **NOTE:** The Decelinator™ can operate between 100 to 220 (30.80 to 67.07 meters) feet maximum. Make sure that the Fly Wire™ is perfectly straight and aligned with the Decelinator™. We do offer 320 feet as an option. If your zipline is equipped with this optional length, you may not operate further than 320 feet (97.60 meters).



CAUTION: DO NOT set up or operate the Fly Wire™ at an angle from the Decelinator™. Failure to operate in a straight fashion can result in serious injury and cause severe damage to the Fly Wire™.



CAUTION: Never place the zipline in an area to be operated in close proximity to overhead obstacles, such as power lines, trees or roof eaves, that may interfere with operation of the mobile Fly Wire™. **Never** place the Fly Wire™ in close proximity of overhead electrical power lines, of any type, at any time. **Never** place the Fly Wire™ where participants will zip over crowds and/or obstructions.



CAUTION: DO NOT set up the Fly Wire™ on soft ground or other unstable surfaces. **DO NOT** lower the jacks onto soft ground, sand or other unstable surfaces.

4.2. Offloading the Decelinator™ From the Trailer

Ensure that the Fly Wire™ winch, located towards the tongue end of the trailer, is connected to the Decelinator's™ loading hook. Make sure the winch is securely fastened to the load hook on the Decelinator™. Also ensure there is little to no slack when the winch's cable is attached to the loading hook.

Remove the safety chain from the Decelinator™.



NOTE: You may raise the trailer before or after this step.



Partly Raise the Fly Wire™ tower to give clearance for removal of the Decelinator™

Attach the hydraulic lift pump controller. Insert the metal plug attached to the controller to the controller socket attached to the pan of the trailer base (located between the lift rams towards the tongue-end of the trailer). The socket is found next to the lift pump, between the lift rams, near the tongue. Raise the protective cover off the socket and fully insert the controller plug.

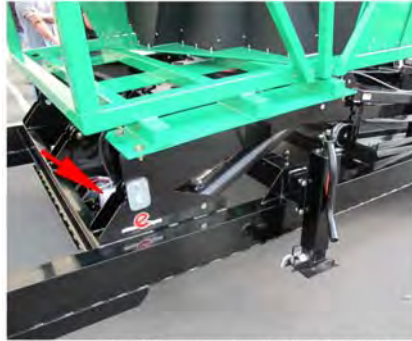

Locate the lift pump between the two lift rams, towards the tongue of the trailer.



Raise the protective cover off the socket to attach the lift controller.



Make sure to align the notch on the plug with the socket to successfully insert the controller.



Connect controller.



NOTE: The ramp chains must first be removed, since the next description is as if you're already raising it.

Press up on the controller toggle switch to raise the Fly Wire™. While the Fly Wire™ platform is raising, listen for any abnormal sounds. Watch the Fly Wire™ as it raises to ensure it continues to raise and is raising at its normal speed.





Partly raise the Fly Wire™ until it is fully off the trailer, providing enough space to lower the steel ramps and offload the Decelinator™. Do not disconnect the towing vehicle from the trailer. The towing vehicle will securely hold the trailer in place and also still be needed to tow the Fly Wire™ trailer forward from the Decelinator™. If clearance is still needed, raise the tower.



Once the tower is partly raised, lift the steel ram stop from the side of the trailer and place it under the Fly Wire™ tower. This is a safety precaution to prevent the tower from lowering back onto the trailer.



CAUTION: RAMP CHAINS MUST BE REMOVED before raising tower. Failure to do so will cause major damage to the Fly Wire™ trailer and/or lift pump.



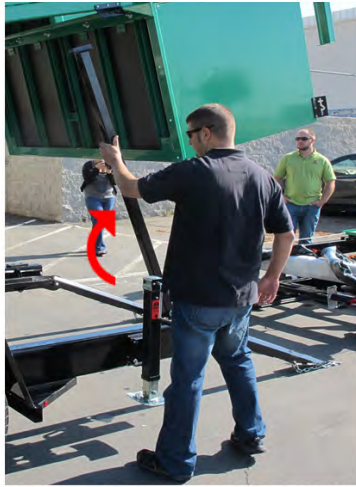

Raise the steel ram stop, bolted to the trailer, underneath the Zippin Zone platform. Lower the platform onto the ram stop.



CAUTION: DO NOT leave the tower partly raised without the steel ram stop in place. Leaving the tower partly raised without the steel ram stop in place may result in serious injury and/or death. You assume all risk and hold Extreme Engineering harmless for any injuries and/or death by failing to use the steel ram stop.



CAUTION: DO NOT continue to lower the tower once it rests on the steel ram stop. Forcing the tower to continue lowering with the steel ram stop in place will cause damage to the ram stop and trailer.

Raise the Fly Wire™ to the vertical position in one *continuous* motion. Try to avoid pressing the UP button multiple times during the raise cycle.

If the Fly Wire™ is raising slower than normal or the pump sounds like it is laboring to raise the Fly Wire™, this could be a sign of a weak charge on the battery.

In an emergency, to raise the Fly Wire™ with a weak battery, the battery can be hooked up to the tow vehicle battery temporarily to complete the raise cycle with jumper cables. Once the Fly Wire™ has been raised successfully, remove the jumper cables from the battery and connect the towing vehicle back to the Fly Wire™ trailer.

Lower the steel ramps so that the Decelinator™ can be lowered onto the ground.



Load / Offload Ramps



Disconnect the loading ramp safety chains from the tower's brackets on both sides.

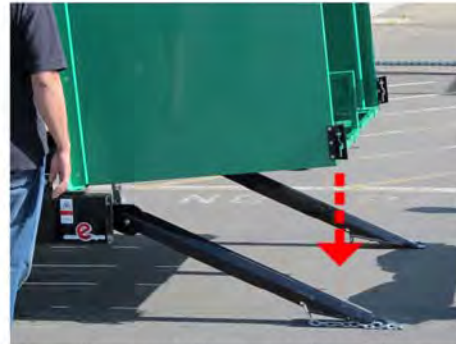

Lower the ramps to the ground. Ensure that the chains are free and clear from getting caught on the trailer or Decelinator.



Ensure that the tower is resting on the steel ram stop and remove the safety chain from the load hook on the Decelinator.

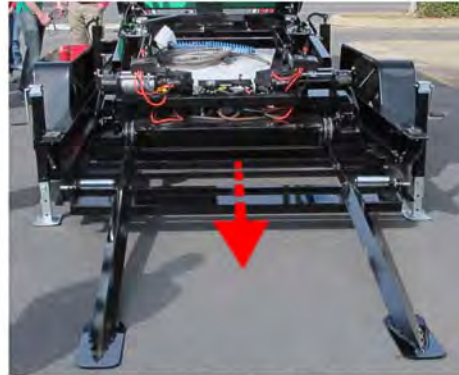

Now that the ramp is on the ground, prepare to lower the Decelinator to the ground with the trailer's winch.

Slowly release slack from the Decelinator's™ winch by engaging the release switch on the winch, plugging in the winch controller and holding the “out” button to release cable from the winch. Safely and slowly lower the Decelinator™ down the integrated track system and to the end of the trailer. Continue to release slack while slowly lowering the Decelinator™ to the ground. (refer to steps below).

Disconnect the winch's cable and slowly pull the trailer forward, lowering the Decelinator™ to the ground.



Lowering the Decelinator with winch



Button can either bring in "IN" the cable slack or "OUT" release cable from winch.



Plug in the winch controller.



Free the spool on trailer's winch. Press the "out" button to release the cable slowly to the ground.



Slowly release the slack from the winch to lower the Decelinator to the ground.



Once the Decelinator is firmly resting on the ground, remove the winch's hook from the load hook on the Decelinator.



Fold the steel ramps back to the towing position.



Turn the trailer's winch counter-clockwise to the "Engage" position. Hold the "IN" button on the controller to slowly bring the cable slack. Remove the controller and safely store away.



CAUTION: DO NOT operate the Fly Wire™ without clearing the surface from small debris (small rocks, trash, screws, etc.). Operating the Fly Wire™ without clearing the surface from small debris can cause the Decelinator™ to move and not allow the friction plates to rest firmly on the landing surface. There should **NOT** be any debris between the product and landing surface.



NOTE: The Fly Wire's™ winch controller looks similar to the Decelinator's™ winch controller, however, these controllers are not universal and will not work if swapped. The winch controller for the Decelinator™ has a yellow marker.



4.3. Attaching Zip Cords to Fly Wire™ tower



Slightly raise the tower and lower the steel ram stop back onto the trailer. Lower the tower back onto the trailer.

Remove the steel ram stop from the Fly Wire™ platform by slightly raising the tower. Place the steel ram stop back into the storing position and lower the tower back onto the trailer.



CAUTION: DO NOT tow the Fly Wire™ with the platform still partly raised. Ensure that the platform is down and in the full towing position, resting on the trailer.

Tow trailer forward and away from the Decelinator™



Measure the distance from the end of the Decelinator™ and towards the tongue of the trailer between 100 to 220 feet (30.86 meters to 67.07 meters). You can have the distance range from 100 to 220 feet (30.86 to 67.07 meters). See diagram above for reference. Always keep a measuring tool with the Fly Wire™ during setup.



NOTE: 220 feet is the maximum length for the standard equipped Fly Wire™. 300 feet is optional.



CAUTION: It is imperative that you **DO NOT** exceed 220 feet or setup under 100 feet for proper operation. There is a red indicator coated on each zip cord to warn you from exceeding the zip cord length. The red indicator should not be past the cable clamp on the



Decelinator™. Failure to operate between 100 to 220 feet will result in serious injury and cause severe issues to the Fly Wire™.



CAUTION: DO NOT have the zipline cords attached to the Fly Wire™ platform when pulling the trailer forward from the Decelinator. Having the zipline cords attached to the Fly Wire™ platform when pulling the trailer forward from the Decelinator™ can cause severe damage to the unit.

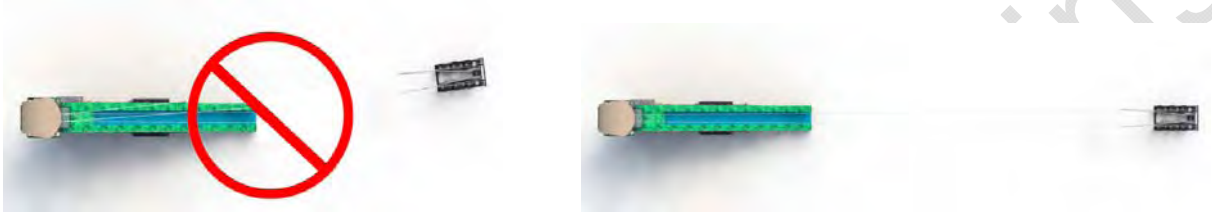

Tow the Fly Wire™ forward to the designated zipline length (between 100 to 220 feet, 300 feet if option equipped) and place the towing vehicle in park. Ensure that you drive straight and not off to the side of the Decelinator™ to keep the zip lines as straight as possible.



Connect zip cords to Decelinator™

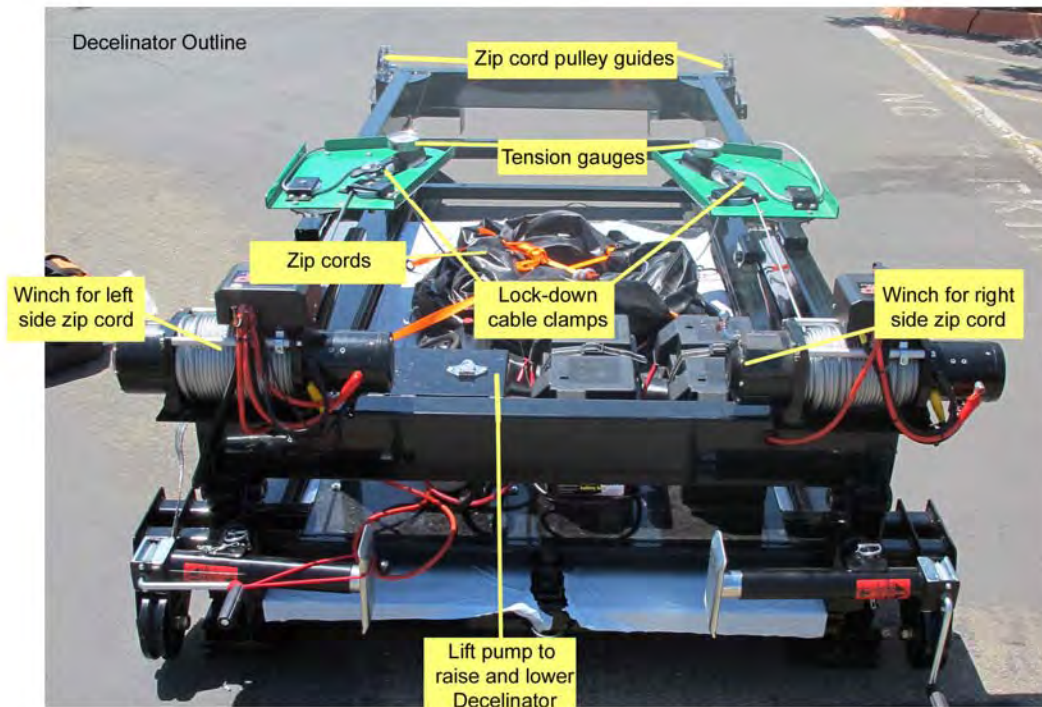

1 Locate the two winches on the Decelinator.



2 Activate the "Free Spool" option on the Winch by pulling the lever towards you or where it is indicated on the winch.

Activate the "free spool" switch on the winch to freely release slack. Start pulling out some slack from the winch so you can easily install the cords on the Decelinator™. Make sure you do not tangle the cords (see above).



CAUTION: ENSURE that during operation of the zipline that operators do not come into close contact with the winch handle, accidentally putting the winch into "free-spool" mode. This can cause serious injury to the Fly Wire™ and a potential catastrophic



failure. You assume all risk and hold Extreme Engineering harmless from any injuries and/or death by failing to abide by the safety procedures in the manual.

Installing Zip Cords on Pulley Guides

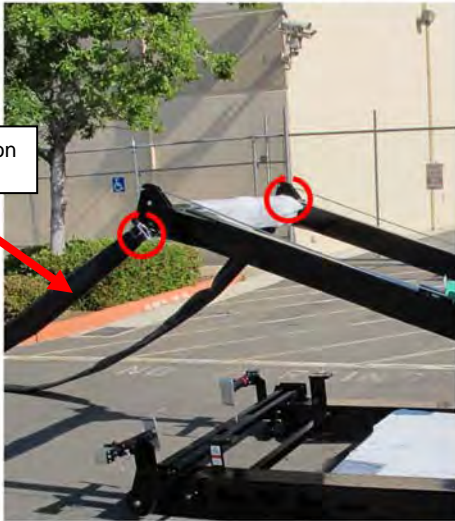

There are pulley guides on the left and right side of the Decelinator to freely guide the zip cords to the Zippin Zone platform. This must be installed before operation.

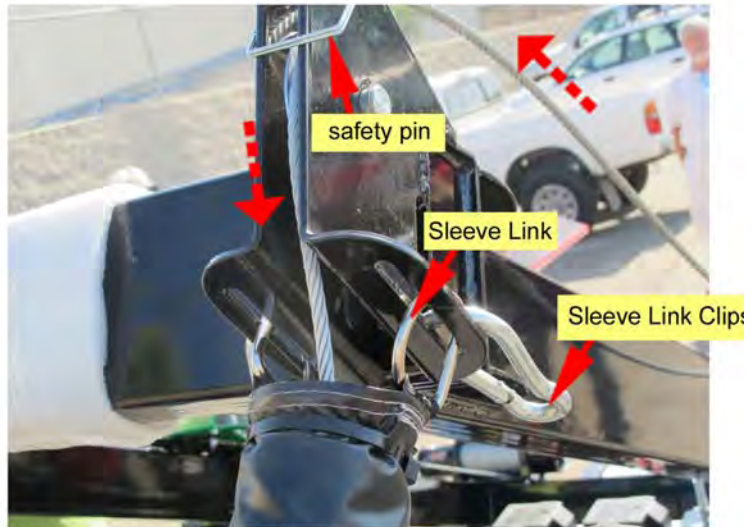

Pull the safety pin and run the zip cords over the pulley. Place the safety pin back into place, along with the sleeve link clips, and lock the safety pin to secure the zip cord. Repeat this step for the 2nd line.

Properly install both of the zip cords through the Decelinator's™ pulley guides and install the compression spring sleeve clips, to hold the sleeves in place, before attaching the zip cords to the Fly Wire™.

Ensure that the safety pin is securely locked into place above the pulley guides (see above).

Inspect the cable assemblies and entire Decelinator™ for signs of wear and/or potential damage before and after each use. Visually inspect the tension plates, gauges and pulleys for signs of wear. Check that the pulleys grooves are not worn. If there are signs of wear, replace worn parts. Refer to the maintenance portion of this manual for additional inspection details. Please contact customer service at 916-663-1560 for additional support.



CAUTION: DO NOT operate the Fly Wire™ without the zip cords correctly installed through the pulley guides and with the safety pin locked into place. Operating the Fly Wire™ without the zip cords correctly installed through the pulley guides and with the safety pin locked into place can cause serious damage to the Decelinator™. If the safety pins are missing, do not operate until you replace them.



CAUTION: DO NOT operate the Fly Wire™ without the compression spring sleeves installed. Operating the Fly Wire™ without the compression spring sleeves installed can expose potential pinch point hazards.





CAUTION: DO NOT operate the Fly Wire™ without clearing the surface of small debris (small rocks, trash, screws, etc.). Operating the Fly Wire™ without clearing the surface of small debris can cause the Decelinator™ to move and not allow the friction plates to rest firmly on the landing surface. There should **NOT** be any debris between the product and landing surface.



CAUTION: YOU MUST ONLY USE Extreme Engineering zip cords when replacing your zipline cords. Aftermarket rope, cords and/or cable will not function properly, will cause severe damage to your Fly Wire™ and serious injuries or death. Extreme Engineering uses an exclusively designed steel cord specifically designed for the Fly Wire™. DO NOT USE ANYTHING ELSE BUT Extreme Engineering zip cords. You assume all risk and hold Extreme Engineering harmless by failing to follow the safety procedures in this manual.

Cords should be replaced every 12 calendar months from date of manufacture or 10,000 zip cycles (a zip cycle is once down the Fly Wire™ zipline and off the Decelinator™) per pair (or 5,000 per cord), whichever comes first, even if there are no visual signs of wear. “If in doubt, swap it out.”

Raise the Decelinator™

Extend the two outriggers on the Decelinator™ to stabilize the Decelinator’s™ platform (see image below).

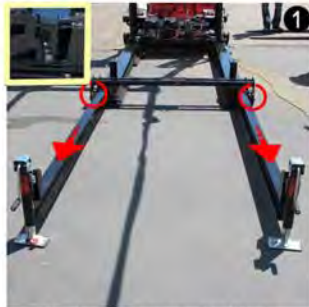

1
Pull the pop-pins up and slide both outriggers away from the Decelinator until both pop-pins lock back into place.



2
Ensure that the stabilizing jacks are properly attached to the outriggers and the legs are resting firmly on the ground. Pin the jack into place and turn the jack handle clockwise to lower the drop leg.

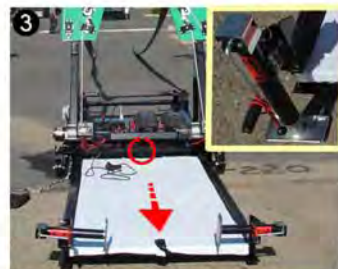

3
Once the outriggers are extended, pull up on the pop-pin and slide out the rear tray to prepare for counterweights. Make sure the stabilizing jacks are properly attached (refer to step 2).



After the outriggers have been extended and the jacks are firmly resting on the ground, slide out the extend tray by pulling up the pop-pins (similar to the outriggers) until the tray locks into place. Pin jacks into place (similar to the outriggers) and lower the jacks until they rest firmly on the ground (see diagram below).

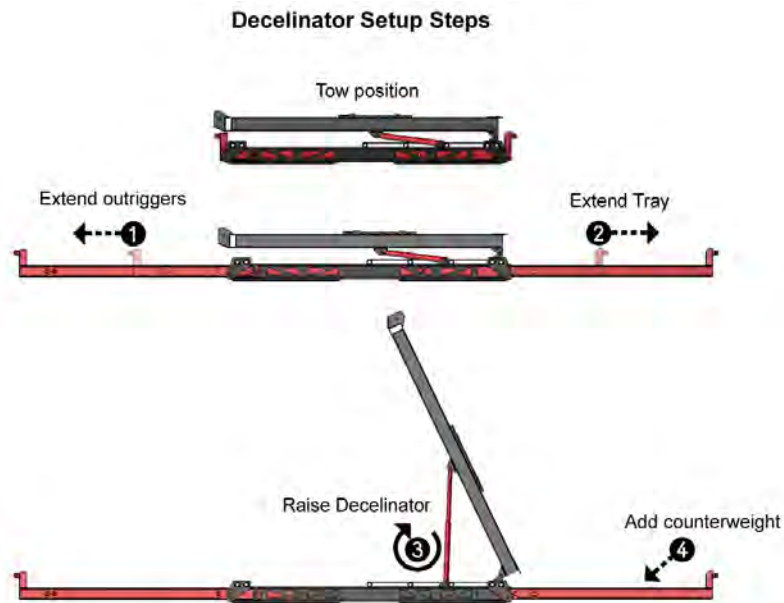

Familiarize yourself with the Decelinator's™ hydraulic pump. The pump's sole purpose is to raise the zip cords high enough in the air for participants to safely zipline and also to lower zipliners safely to the ground when they finish the zipline ride.

The Decelinator's™ lift controller has a yellow marker to indicate that it is used for the Decelinator's™ pump only. All other controllers will not work correctly on the pump. There is an emergency shut-off switch on the pump which will also cut the power.



NOTE: Some Fly Wire™ Zipline owner's may have a Decelinator with a front tray as well as a rear tray. This is typically for operators who own the 300 foot option. If you have a front tray you may also place counterweights here



Decelinator Pump Overview

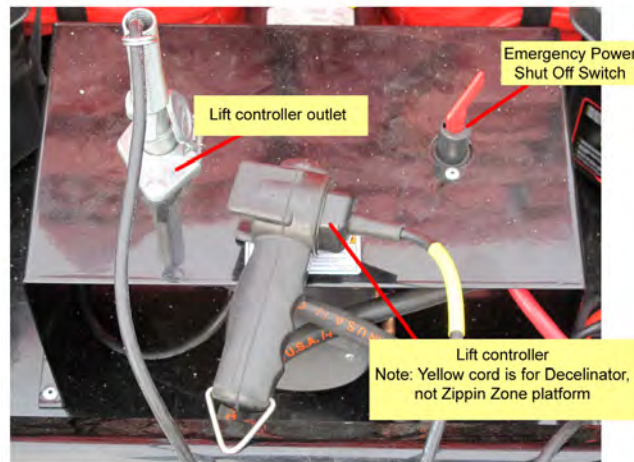

Raise the Decelinator™ until it is in the fully upright position (see image below).

Raising Decelinator



Plug in the Decelinator's lift controller (yellow cord) and make sure the emergency switch is not on.



Raise Decelinator by pushing the toggle switch up.



Raise the Decelinator until the lift rams can no longer raise the zip cords up in the air.

Inspect the Extreme Engineering zip cords and ensure they are not twisted or tangled on the Decelinator™, Fly Wire™ trailer and/or platform. Ensure that the Decelinator™ is on a level surface and no debris (small rocks, trash, screws, etc.) are between the Decelinator's™ base and surface.





Do not tangle or cross the zip cords.



CAUTION: DO NOT operate the Fly Wire™ without clearing the surface of small debris (small rocks, trash, screws, etc.). Operating the Fly Wire™ without clearing the surface of small debris can cause the Decelinator™ to move and not allow the friction plates to rest firmly on the landing surface. There should **NOT** be any debris between the product and landing surface.



NOTE: The Fly Wire's™ winch controller looks similar to the Decelinator's™ winch controller, however, these controllers are not universal and will not work if swapped. The Decelinator's™ winch controller has a yellow marker.

Connect zip cords to the Fly Wire™ platform

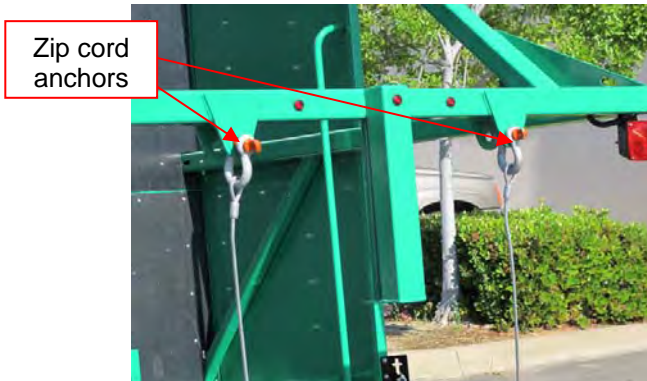

Locate the zip cord anchors at the end of the trailer and above the platform.



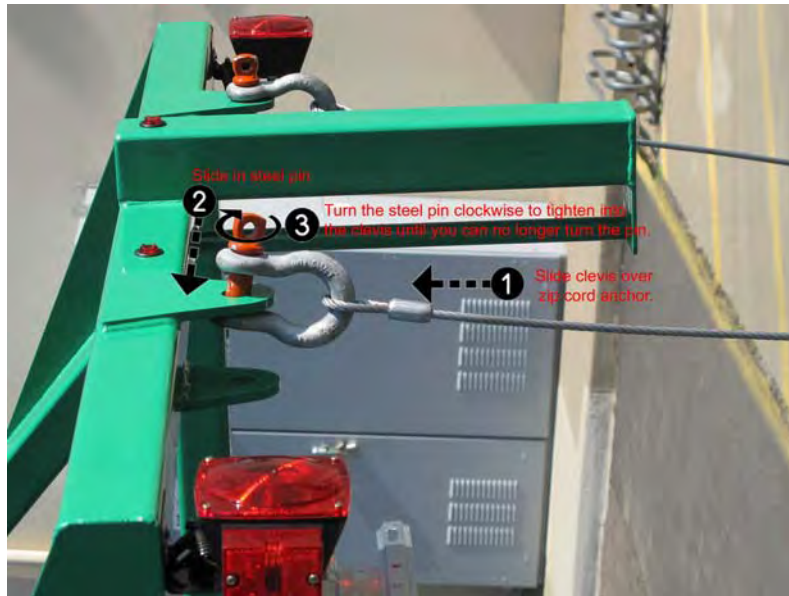

Stretch each Extreme Engineering zip cord to the top of the Fly Wire™ platform. Locate the zip cord anchors on the sides of the Fly Wire™ platform. Connect both of the Extreme Engineering zip cords to the Fly Wire™ platform. Ensure that the steel pins are both correctly tightened into place, securely locking the clevises to the Fly Wire™.

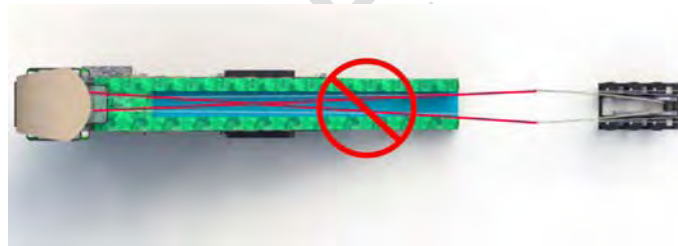

Don't cross the Extreme Engineering zip cords and connect them to the opposite ends of the steel anchors. Keep the left zip cord to left side of the Fly Wire™ platform and the right zip cord to the right side. (See diagram above).





Ensure that the winch is in the "Free Spool" position when raising the Zippin Zone Platform.

Once the Extreme Engineering zip cords are connected to the zipline platform ensure that the Decelinator's winches are still in the "free spool" position.



CAUTION: DO NOT engage the Decelinator's™ winches or lock the cable before raising the Fly Wire™ platform. This can cause severe tension on the cable, lift the Decelinator™ and/or cause serious damage to the trailer.



CAUTION: DO NOT drive over the zip cords with your towing vehicle. Keep towing vehicles and/or forklifts clear from the zip cords when they are resting on the ground. If the zip cords are run over, this will cause severe damage and require replacement of the cords. **DO NOT** operate the Fly Wire™ if the cords are damaged.



CAUTION: ENSURE that during operation of the zipline that operators do not come into close contact with the winch handle, accidentally putting the winch into "free-spool" mode. This can cause serious injury to the Fly Wire™ and a potential catastrophic failure. You assume all risk and hold Extreme Engineering harmless from any injuries and/or death by failing to abide by the safety procedures in the manual.



CAUTION: For your safety, read all instructions before raising the mobile Fly Wire™ for operation.

4.4. Unhitch Tow Vehicle

Block the wheels of the trailer with blocks or wheel chocks to keep the Fly Wire™ from moving when unhooked from the tow vehicle.



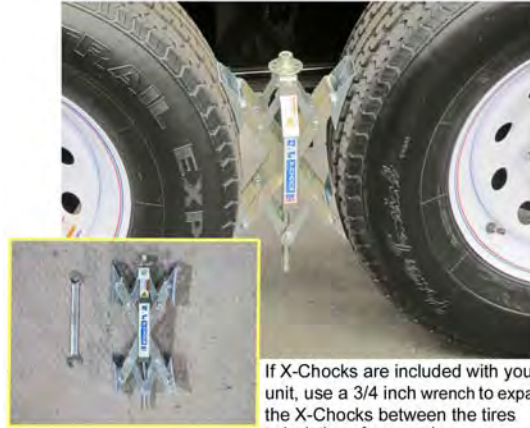

If X-Chocks are included with your unit, use a 3/4 inch wrench to expand the X-Chocks between the tires to lock them from moving.

Set the front jack for removal of the Fly Wire™ from the tow vehicle. Pull the pin holding the tongue jack in the horizontal travel position. With the foot of the jack near the ground, replace the pin holding the leg to the jack.



Unhook all towing components. Disconnect the electrical plug, the emergency brake break-away lanyard (if applicable), the towing safety cables and the safety hitch pin.



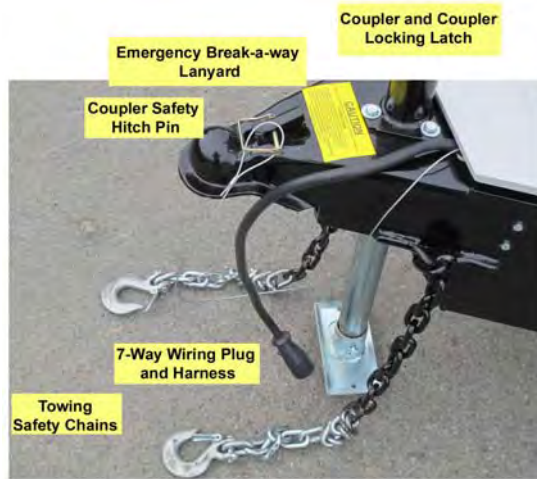

Release the coupler latch handle. Remove the coupler safety hitch pin from the coupler latch handle. Pull up on the latch handle safety lock and then lift the coupler latch handle 90 degrees to the fully vertical position.

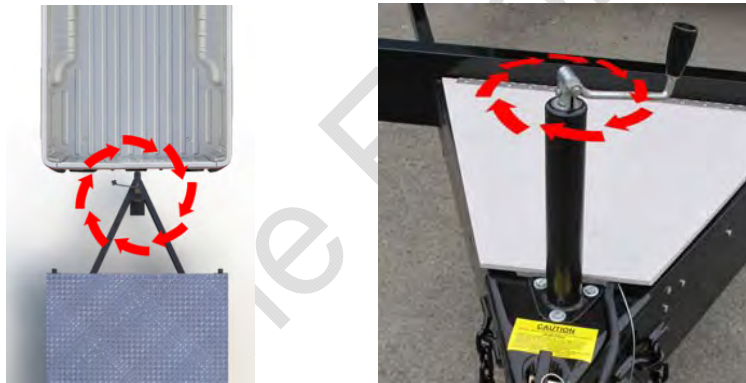

Raise the coupler up off of the tow vehicle hitch ball. This is accomplished by rotating the jack handle on the jack clockwise. Rotate the jack handle until the coupler is completely up off of the ball. Ensure there is enough clearance between the ball and the bottom of the coupler to allow the tow vehicle to be driven away without catching the coupler.

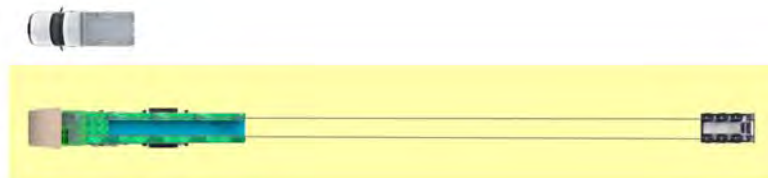

Move the vehicle away from the operational area. **Park the tow vehicle.**





4.5. Prepare the Fly Wire™ For Raising



CAUTION: For your safety, read all instructions before setting up the mobile Fly Wire™ for operation.



CAUTION: DO NOT operate the Fly Wire™ without clearing the surface of small debris (small rocks, trash, screws, etc.). Operating the Fly Wire™ without clearing the surface of small debris can cause the Decelinator™ to move and not allow the friction plates to rest firmly on the landing surface. There should **NOT** be any debris between the product and landing surface.

Move jacks (including the two outrigger jacks) from their travel position to their operational position

Raise the jacks by rotating the handle clockwise until the drop legs touch the ground. Make sure all jacks are resting firmly on the ground, without raising the trailer. **DO NOT** raise the wheels off of the ground. The purpose of each jack is to stabilize the Fly Wire™ trailer from movement (see images below).





1 Locate all four stabilizing jacks.



2 Pull safety lock clip from drop leg pin.



3 Allow drop leg to rest on ground and replace pin back into drop leg.

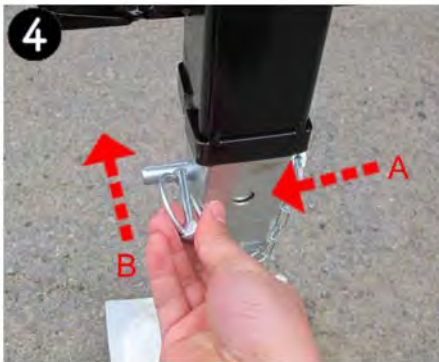

4 Securely lock the pin with the safety lock pin.



5 Turn jack handle clockwise to lower the jack leg to the ground.



6 Ensure that the jack rests firmly on the ground, not raising the tires off the ground.



NOTE: The Fly Wire™ trailer already has enough clearance when raising the tower in the up position. The tower will raise on top of the trailer's base and need clearance from the trailer base.

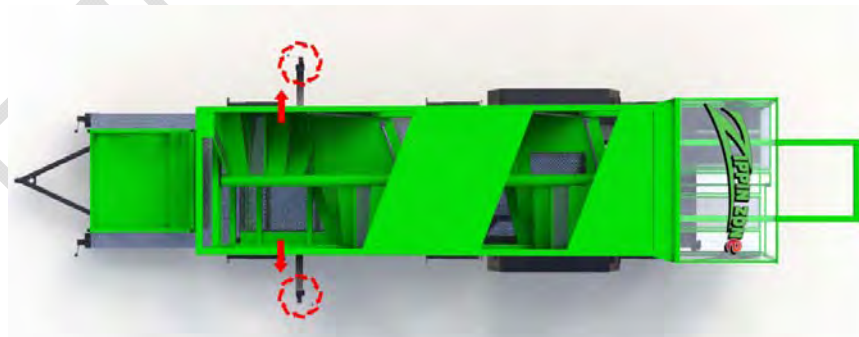

Extend the two outriggers, located toward the tongue end of the trailer, by pulling up on the pop-pin. Hold the pop-pin up while sliding out each outrigger. Rotate the handles on each jack until the drop legs rest firmly on the ground (see image below).



Setting outriggers into the operating position.



Pull up the pop-pin to allow the outrigger to slide back towards the trailer.



Slide the outrigger out from the trailer until the pop-pin locks back into place.



Pull release hook to drop leg to the floor. Keep your feet clear! Ensure that the drop leg locks.



Turn jack handle clockwise until the jack firmly rests on the ground. Make sure there is no debris under the foot of the jack. Repeat step on other outrigger.



NOTE: Failure to hold the pop-pin up while sliding out each outrigger will severely scratch the powder coat on the outriggers and possibly cause rust.



CAUTION: DO NOT operate the Fly Wire™ without the outriggers in the operational position. Operating the Fly Wire™ without the outriggers in the operational position can result in movement of the zipline and cause damage to the product. Failure to do so can also cause potential injuries while in use.

Ensure that the Fly Wire™ is level from both the side view as well as the rear view. When the jacks are firmly resting on the ground, check that the wheels do not spin freely. The jacks should not raise the trailer and only be firmly resting on the ground for stability (see image below).



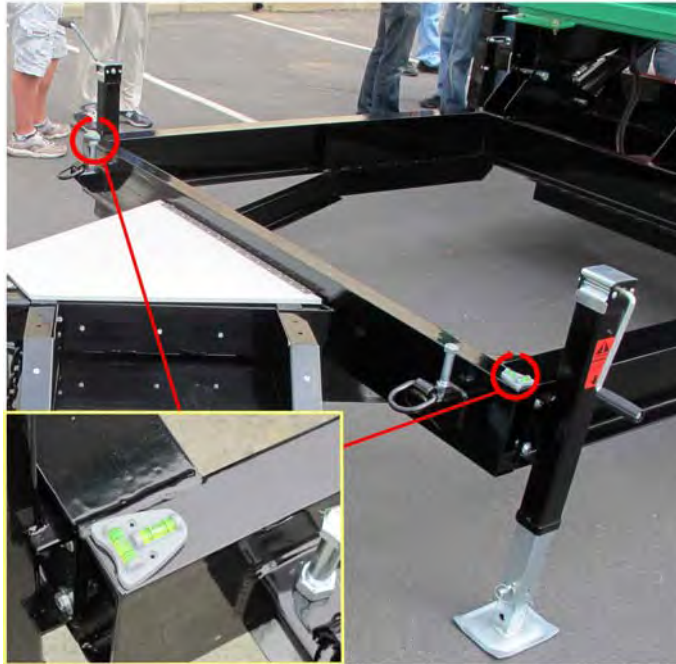

Levels, if equipped, are located on the left and right side of the tongue end of the trailer.

Installing additional staircase to trailer

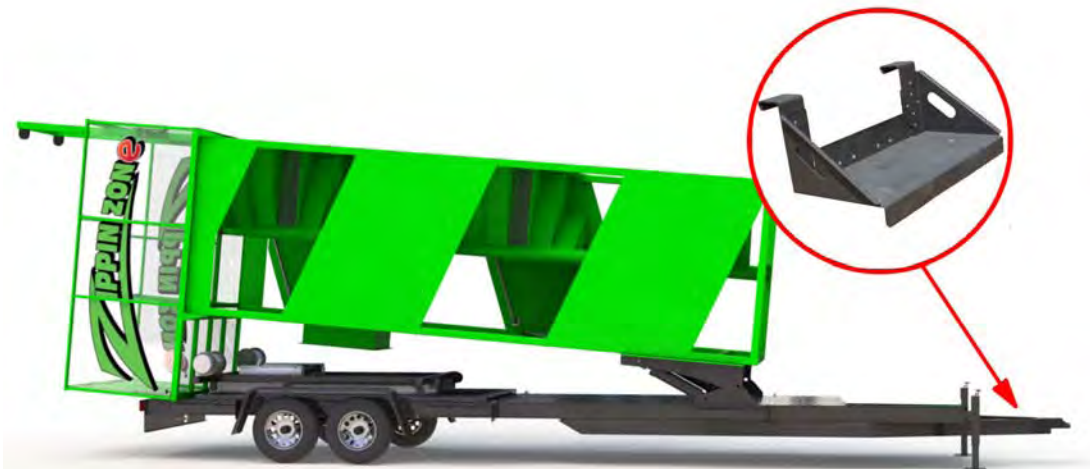

Mounting staircase to the trailer

Installing additional staircase



Remove the additional staircase, located behind the tongue of the trailer, from the storing position and prepare to hook it into the side of the trailer.



Hook the staircase into the notches on the side of the tongue of the trailer. The staircase will firmly rest against the trailer.



Final view with staircase installed and Zippin Zone platform raised.



CAUTION: Do not use the Fly Wire™ without the staircase mounted and in the operational position. Do not attempt to step on top of the trailer instead of using the staircase when entering the zipline tower.

4.6. Raise the Fly Wire™ tower



CAUTION: RAMPS MUST NOT be attached with chains to Fly Wire™ tower before raising. Failure to remove safety chains from tower will cause severe damage to Fly Wire™ trailer and/or pump.

Attach the hydraulic lift pump controller. Insert the metal plug attached to the controller to the controller socket attached to the pan of the trailer base. The socket is found at the side of the trailer, in front of the fenders, near the tongue. Raise the protective cover off the socket and fully insert the controller plug.



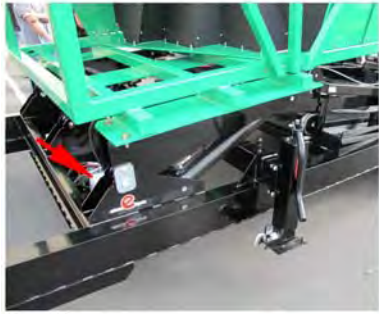

Locate the lift pump between the two lift rams, towards the tongue of the trailer.



Raise the protective cover off the socket to attach the lift controller.



Make sure to align the notch on the plug with the socket to successfully insert the controller.



Connect controller.

Raise the Fly Wire™ tower with the controller. Press up on the controller toggle switch to raise the Fly Wire™ tower. While the Fly Wire™ platform is raising, listen for any abnormal sounds. Watch the Fly Wire™ tower as it raises to ensure it continues to raise and is raising at its normal speed.



Raise the Fly Wire™ tower until it is fully upright in the vertical position. Watch the base frame of the trailer and Fly Wire™ tower to ensure that it will rest firmly on the trailer when approaching and completing its final vertical position.





Raise the Fly Wire™ to the vertical position in one *continuous* motion. Try to avoid pressing the UP button multiple times during the raise cycle. **DO NOT** continue to force the Fly Wire™ any further than its complete vertical position. This can cause damage to the frame and trailer.

Stop raising the Fly Wire™ platform once the base of the platform rests firmly on the stops (see image below).

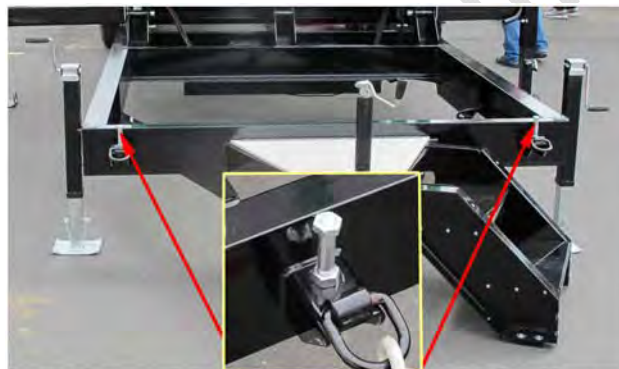

The Zippin Zone Platform Stops are located on the left and right side of the tongue end of the trailer. When the platform is raised it will rest firmly on these stops.



The Zippin Zone Platform in the operational position resting on the platform stops.



NOTE: In rare occasions the platform stops may need slight adjustment so that the Fly Wire™ platform rests firmly on the trailer.





In rare occasions the Platform Stops may need to be adjusted so that the Zippin Zone rests firmly on both of the stops. You will need two crescent wrenches to adjust the Platform Stops, one on the nut and the other on the bolt.

Attach the turn buckles on the Fly Wire™ platform to the trailer using the load hooks. You can adjust the tension (tighten or loosen) on the turn buckles by turning the center of the turn buckles.

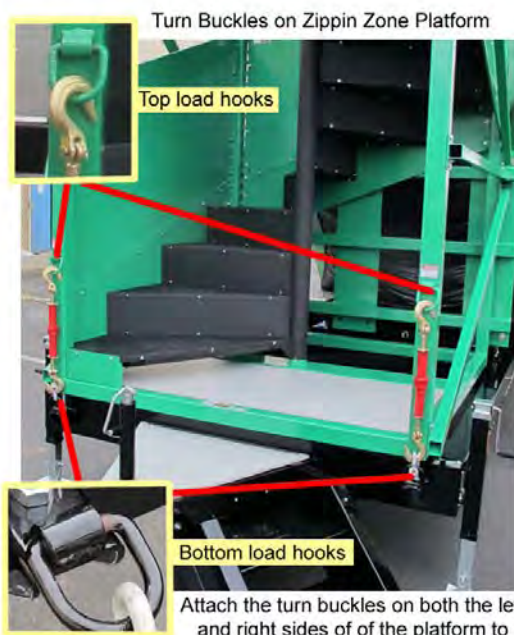

Attach the turn buckles on both the left and right sides of the platform to the load hooks.



Turn buckle stops can be adjusted to rest above and below the turn buckle to prevent untwisting.

Turn buckle can be adjusted by twisting.



NOTE: If the Fly Wire™ is raising slower than normal or the pump sounds like it is laboring to raise the Fly Wire™, this could be a sign of a weak charge on the battery.

In an emergency, to raise the Fly Wire™ with a weak battery, the battery can be hooked up to the tow vehicle battery temporarily to complete the raise cycle with



jumper cables. Once the Fly Wire™ has been raised successfully, remove the jumper cables from the tow vehicle and move the it away from the operational area.

If the Fly Wire™ had to be raised with the help of the tow vehicle battery, it will also require help when lowering. The default operation of the pump is to raise the Fly Wire™. When battery power drops below a sufficient level, the direction control module will not engage when the pump is running. The direction control module reverses the flow direction of the hydraulic oil and this causes the Fly Wire™ to lower. If the direction control module does not engage, the pump will only attempt to lift the Fly Wire™ further. It will not lower.

It is also possible that there is sufficient charge to raise the Fly Wire™ with the battery, but the raise operation drains the battery enough so that it won't lower due to the inability to engage the direction control module while the pump motor is running. In both of these cases, you will have to connect the tow vehicle battery to the Fly Wire™ battery to lower the Fly Wire™.

Attaching the tow vehicle battery to jump the Fly Wire's™ battery is the same as jumping another vehicle that will not start. Attach the positive jumper cable lead to the positive post on the mobile Fly Wire's™ battery. Attach the negative lead to the negative post on the Fly Wire's™ battery.



CAUTION: DO NOT touch each other or any portion of metal on either the Fly Wire™ or the tow vehicle inadvertently. Attach the positive lead to the tow vehicle's positive battery post. Lastly, attach the remaining negative lead to a good solid metal ground point on the tow vehicle. Start the tow vehicle and then lower the Fly Wire™ using the controller. Carefully disconnect the leads by first disconnecting the negative cable from the vehicle ground point and the positive battery post. Remove the negative lead from the Fly Wire™ battery and then remove the positive lead from the battery.



CAUTION: DO NOT smoke or have an open flame near batteries. Smoking or have an open flame near batteries can result in serious injury.

A good battery will provide from four to eight lift cycles before requiring charging. The number of lift cycles depends on the age of the battery and frequent charging of the battery. Extreme Engineering recommends starting each usage season with new battery. Having a secondary backup battery that is always fully charged is also a good preventative measure for low battery charge conditions that may occur during operation.



NOTE: Some battery issues can occur with the Decelinator™ if not properly charged. Use the same troubleshooting methods above when dealing with drained battery issues on the Decelinator™.





Raise the protective cover on the lift pump and grab the steel end of the lift controller .



Remove the lift controller. Do not pull from the cord. This can damage the lift controller.

Remove the controller from the Fly Wire™™. Once the Fly Wire™ has been fully raised into its operational position, remove the Fly Wire™ lift controller from the controller socket. Store the controller in a safe place that will guarantee it cannot be reattached and/or activated during the zipline event for the zipline platform.



NOTE: You will need to keep the Decelinator™ controller plugged into the Decelinator™ at all times during operation of the zipline.

Push on the Fly Wire™ platform both sideways and front to back. This operation will ensure that the Fly Wire™ platform is settled completely down on its resting location. If the Fly Wire™ can be rocked by hand in either of the two directions, the Fly Wire™ will either need to be relocated to a more level surface, the stabilizing jacks and outriggers will need to be adjusted. Shims are not allowed.



The Fly Wire™ should ideally be at exactly 90 degrees vertical, when viewed from the front/back view and left/right side to side view.



4.7. Inflatable Slide Setup (optional)



The optional inflatable slide provides an additional exit strategy on the Fly Wire™ product and also another attraction with the zipline. The sole purpose of the inflatable slide is to give participants the option to slide or exit if they are too scared to complete the zipline ride. The inflatable is not needed for proper operation and is an option that can be purchased with the Fly Wire™ product.

If your Fly Wire™ is equipped with an inflatable slide, there are several additional steps in the setup process. Follow all safety procedures when slightly raising the wall, including using the steel ram stop, when installing the inflatable.



NOTE: Inflatable Slide is not approved for use in New Jersey.



NOTE: Always use a vinyl tarp (not included) underneath the inflatable slide to prevent holes in the vinyl. Never put the inflatable slide directly on the ground without using a tarp.

- Depending on where the inflatable slide is stored, remove the slide from either the towing vehicle or from the rear end of the trailer. Keep a cover over the slide, when stored, to keep it protected from outside elements such as rocks, dust and/or dirt.
- Partly raise the Fly Wire™ and rest the platform on the steel ram stop.
- The inflatable slide is always secured to the Fly Wire™ trailer and does not require sandbags or tent stakes when in operation. The inflatable slides' straps are fully secured to the steel trailer of the Fly Wire™ zipline at all times during operation.



NOTE: Always ensure that when removing or storing the inflatable slide that the vinyl is not folded but tightly rolled. Folding the inflatable will create creases that can cause a tear. Inflatables should always be tightly rolled and strapped in place.

PVC Strip



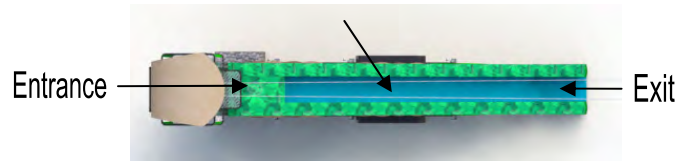

- Roll out the deflated slide and place it on the base of the Fly Wire™ trailer.



NOTE: The Decelinator™ should be off the trailer before attempting to set up the inflatable slide. Ensure that the entrance end of the slide is facing upward and is facing toward the tongue of the trailer.

- Ensure that the slick, PVC strip is applied to the inflatable slide. This allows the participants to slide freely when in use. The PVC strip velcros on the slide. **DO NOT** operate the inflatable slide without the strip. The slide will not function properly without the PVC strip attached. Without the use of the PVC strip, the vinyl becomes very abrasive and can cause “skin burns” or scuff the skin when going down the slide.

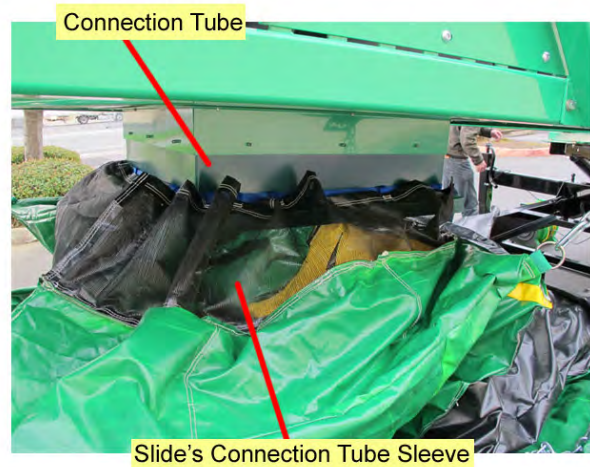
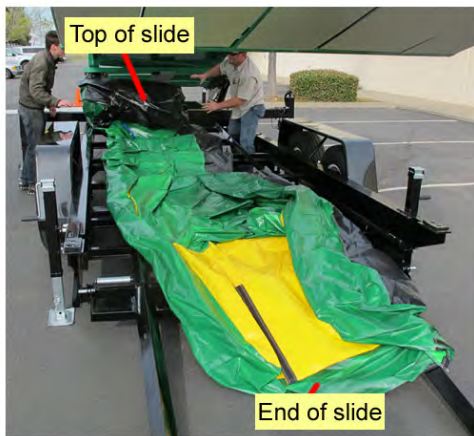

- Place the top side (the entrance) of the slide, where the participants would exit, around the connection tube. With the tie-down strap, tighten the slide's sleeve around the connection tube.





Run the tie-down strap through the tube sock of the slide and tighten the strap around the connection tube. Use the buckle to fasten the strap in place.

- Use the chain links to attach the slide to the Fly Wire™ platform, located on the sides of the connection tube. Ensure that both of the chain links do not have too much slack and are instead pulling, as well as holding, the inflatable slide in place around the connection tube.



Bracket Locations

Connect all 4 chains to the links on the left and right side of the slide.
 NOTE: The brackets are located above and below the connection tube on both sides. Once the slide is connected to the chains, connect the chains to the 4 brackets. Make sure the slack is taken in and securely holding the slide in place.

- Inspect the chains for proper installation. The chains should go through the steel rings located on both the left and right sides of the front and rear end of the connection tube. Once the chains are secure, lock the chain links through the steel brackets (four total) mounted on the Fly Wire™ platform. Each steel bracket contains a notch to hold the chain links in place, eliminating the potential risk of loosening during use.





NOTE: If your Fly Wire™ is equipped with an optional inflatable slide, either the slide or the end cap must be attached at all times during use.

- Place the inflatable blower on the base of the trailer and provide the appropriate power to run the inflatable blower. **NOTE:** the inflatable blower is a 1 HP blower. Do not allow the vinyl to suffocate the air vents of the blower, this can cause severe damage to the blower and also create heat that could potentially melt the vinyl slide and cause a fire hazard.

Strap option as shown. Velcro option is also equipped with some models.



- Connect the inflatable sock tube to the inflatable blower. Make sure the strap is securely fastened around the blower and tight enough to not allow air to escape from the sock tube to the slide. Once the inflatable blower is fastened around the sock tube, turn the power switch on.



NOTE: You may have a velcro option used to tighten the sock tube.

- While the blower is on, raise the Fly Wire™ platform by holding the up/raise switch on the lift controller. Try to raise the Fly Wire™ in one complete movement, without releasing the up switch. Make sure the inflatable slide sits within the center of the base of the Fly Wire™ trailer. The inflatable slide should not be positioned to the sides or kinked in any fashion. Adjustment can be made by pulling the slide from left to right or pulled from front to back.
- Once the Fly Wire™ platform is fully raised, ensure the inflatable slide's chains are still secure and holding the slide firmly in place. Make sure the inflatable slide is still straight and over the trailer. Also make sure that the slide's tube sock is still securely fastened and the inflatable blower is not suffocating from air flow.

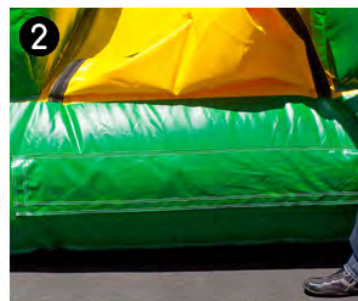

- Make sure the zipper, located at the end of the slide, is zipped and not allowing air to exit the inflatable.



Optional anchor straps for sand bags.

- Optional anchor straps are provided on the inflatable slide in case you are required to anchor to sandbags on top of the installation process (refer to your state requirements for sand bags).



4 D-Rings are located on the base of the inflatable to securely fasten the slide to the trailer's load hooks.

- Secure the base of the inflatable slide to the trailer by using the four load hooks on the trailer. The inflatable slide contains four D-rings and webbing that allow you to secure the inflatable to the load hooks on the trailer.



NOTE: The seams of the slide are designed to allow air to flow through the vinyl. This is purposely designed to prevent the inflatable from popping with too much air pressure. There is also a zipper at the bottom of the slide to release air when deflating the slide.



CAUTION: DO NOT use an aftermarket slide with the Fly Wire™. **YOU MUST ONLY** use Extreme Engineering's factory slide with your Fly Wire™ product. Using an aftermarket slide with the Fly Wire™ may result in serious injury and/or death. Extreme Engineering is held harmless if you modify, change or redesign a slide



structure onto the Fly Wire™ system without approval by Extreme Engineering. You assume all risk with an aftermarket slide or by failing to follow the safety procedures in this manual.



CAUTION: All weather conditions and safety conditions mentioned previously during setup of the Fly Wire™ should also be observed with the inflatable slide.

4.8. Applying counterweight to the Decelinator™



Now that the Decelinator™ is in the upright position, it is imperative that appropriate counterweight is added to stabilize the Decelinator™ and prevent movement. The Decelinator™ includes friction plates on the base of the system to create friction between the Decelinator™ and the landing surface. Depending the type of landing surface you rest the Decelinator™, a certain amount of counterweight and tent stakes will be required.

Please refer to the counterweight chart on page 63.



NOTE: 1 sand bag = 50 lbs (22.70 Kilos)



CAUTION: DO NOT operate the Fly Wire™ without the proper counterweights and tent stakes required for safe operation. **DO NOT** use aftermarket or other methods of counterweight/tent stakes other than the components provided by Extreme Engineering. Failure to abide by the safety procedures outlined in this manual and failure to use OEM Extreme Engineering equipment will void the product warranty. You assume all risk and hold Extreme Engineering harmless from any injuries and/or death by failing to abide by the safety procedures in the manual and failing to use OEM Extreme Engineering equipment.



We recommend using 3,500 lbs, no matter if you use one or two ziplines, during operation. Staking will be required depending the landing surface. Please use the chart on the next page as a reference to assist in determining the counterweight and/or anchoring your Decelinator™ (see chart below). You should always test the Decelinator™ before operation since EVERY situation will be different.

There are a total of 4 tent stakes, 1 in the front of the Decelinator™ and 3 in the rear (see photo below).

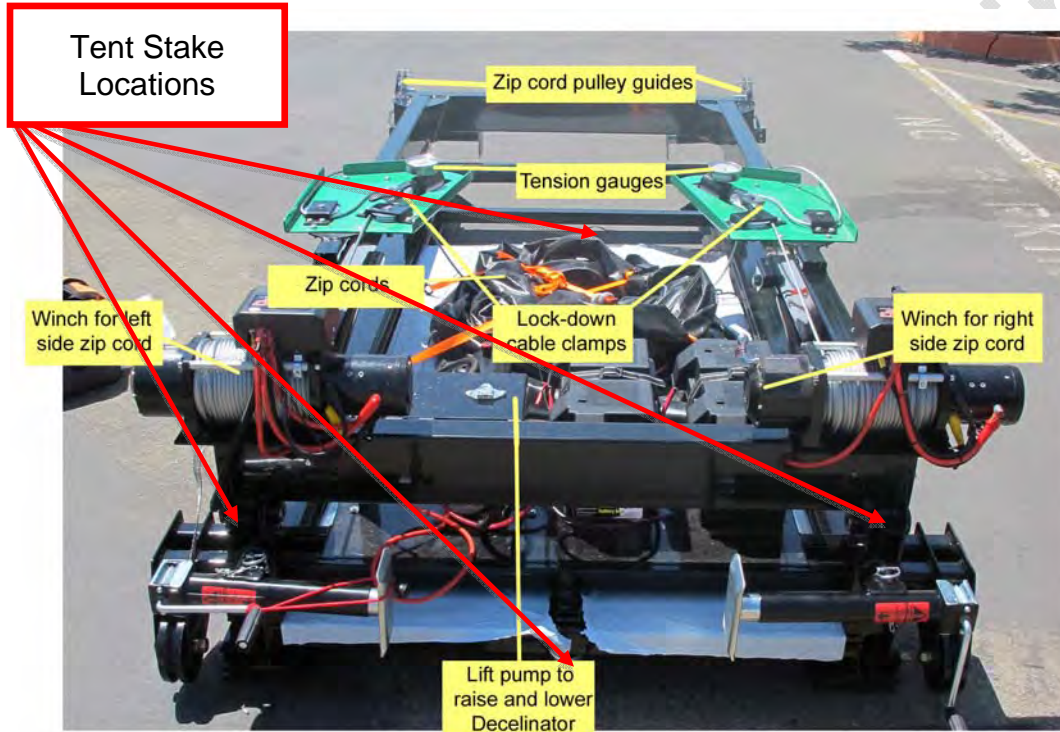





NOTE: If you require tent stakes in addition to using counterweights, please consult with Extreme Engineering on tent stake requirements. Soft surfaces, such as grass and dirt, will vary on the type of tent stakes required. Tent stakes will vary depending on the type of surface. Every operational situation is different, therefore the type of tent stakes will vary. For consulting on tent stake requirements on a particular location, please contact customer support.

Contact customer support at 916-663-1560 for additional assistance.



CAUTION: ENSURE that during operation of the zipline that operators do not come into close contact with the winch handle, accidentally putting the winch into “free-spool” mode. This can cause serious injury to the Fly Wire™ and a potential catastrophic failure. You assume all risk and hold Extreme Engineering harmless from any injuries and/or death by failing to abide by the safety procedures in the manual.



Surface Type	Amount of Sandbags	Tent Stakes
 <p>Asphalt</p>	 <p>70 bags</p>	<p>Optional</p>
 <p>Concrete</p>	 <p>70 bags</p>	<p>Optional</p>
 <p>Grass</p>	 <p>70 bags</p>	
 <p>Dirt</p>	 <p>70 bags</p>	
 <p>Sand</p>	<p>DO NOT OPERATE</p>	<p>DO NOT OPERATE</p>
<p>OTHER TYPES</p>	<p>CALL EXTREME ENGINEERING 916-663-1560</p>	<p>CALL EXTREME ENGINEERING 916-663-1560</p>



4.9. Setting Tension on Decelinator™

TEST BEFORE YOU ZIP



CAUTION: Exercise both of the lines of the zipline by strictly following these test procedures.

The following test procedures should be performed on every Fly Wire™ and Decelinator™ as a part of the setup process prior to using the zipline or after performing maintenance.

When performing this test on a mobile Fly Wire™, you must first raise the Fly Wire™ tower and Decelinator™ to their fully upright operating positions. Follow your mobile Fly Wire's™ Owner's Manual to properly prepare and raise the Fly Wire™.

Prepare to bring in the tension on the zip cords by turning the winch's handles to the "engaged" position.



Activate the "Engaged" option on the Winch by pulling the lever towards you or where it is indicated on the winch.

Plug the winch controllers into the winch and bring in the cable slack so the zip cords start to roll around the winch's spools. Ensure that the cable doesn't bunch up or bind in the center of the winch.



CAUTION: WEAR GLOVES when handling the zip cords. If you don't wear gloves you may snag your fingers on a cable strand and cause bodily injury.



CAUTION: ENSURE that during operation of the zipline that operators do not come into close contact with the winch handle, accidentally putting the winch into "free-spool" mode. This can cause serious injury to the Fly Wire™ and a potential catastrophic failure. You assume all risk and hold Extreme Engineering harmless from any injuries and/or death by failing to abide by the safety procedures in the manual.



While bringing in the slack, carefully watch the tension gauges. Stop bringing in the slack once the tension gauges read between 1,000 to 1,300 lbs. Lock the cable clamp on the cable (refer to image on next page).

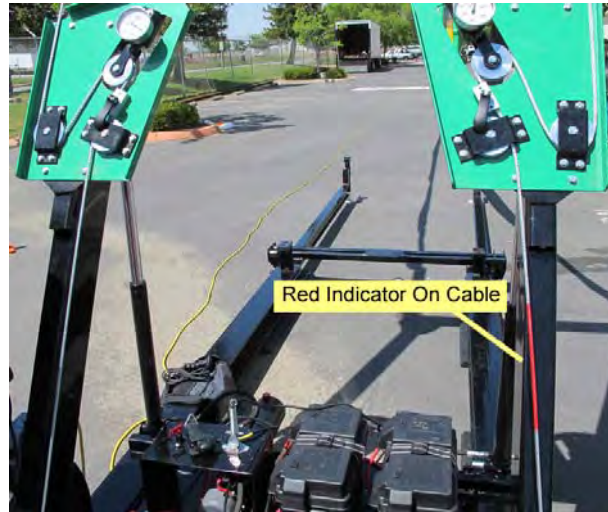

Each zip cord has a red indicator. **DO NOT** allow the red indicator of the cable to be above the cable clamp. The red indicator is to notify you when too much cable is released out of the winch.



1
Locate the socket on the winches and align the winch controller's plug with the socket. Plug the controller into the socket.



2
Push the button down, "in" position, to bring in the slack.



3
Set the tension between 1,000 to 1,300 lbs on the gauges for the correct operating zip cord tension.



4
Lock the cable clamp next to the gauge, to prevent the cable from releasing slack.





CAUTION: DO NOT operate the Decelinator™ with the red indicator past the cable clamp. Operating the Decelinator™ with the red indicator past the cable clamp can cause serious injury to the Fly Wire™ and a potential catastrophic failure. You assume all risk and hold Extreme Engineering harmless from any injuries and/or death by failing to abide by the safety procedures in the manual.



CAUTION: DO NOT operate the Fly Wire™ without clearing the surface of small debris (small rocks, trash, screws, etc.). Operating the Fly Wire™ without clearing the surface of small debris can cause the Decelinator™ to move and not allow the friction plates to rest firmly on the landing surface. There should **NOT** be any debris between the product and landing surface.



CAUTION: ENSURE that during operation of the zipline that operators do not come into close contact with the winch handle, accidentally putting the winch into “free-spool” mode. This can cause serious injury to the Fly Wire™ and a potential catastrophic failure. You assume all risk and hold Extreme Engineering harmless from any injuries and/or death by failing to abide by the safety procedures in the manual.



Applying test weight onto zip cords before operation

Lowering Decelinator



Plug in the Decelinator's lift controller (yellow cord) and make sure the emergency switch is not on.



Lower the Decelinator by pushing the toggle switch down.



Lower the Decelinator until the lift rams can no longer lower the the Decelinator to the platform. **DO NOT** remove zip cords before lowering!

Plug in the Decelinator's™ lift controller and lower the Decelinator™ to the ground until the hydraulic lift rams can no longer lower the Decelinator™. **DO NOT** remove the zip cords from the Decelinator™.



Ensure the zipline pulley is over the zip cord and a carabiner is used to fasten the 250 lbs of weight to the zip line pulley.

*NOTE: Pulley photo is different than actual zip line pulleys provided with product.



Add 250 lbs, using the sand bags, to the zipline pulley with a carabiner. Attach the zipline pulley to one of the zip cords.



NOTE: The Fly Wire™ is designed to handle two zipliners at the same time up to 250 lbs each.



NOTE: You will have to repeat this step if you are operating both zip lines.

Raising Decelinator



Plug in the Decelinator's lift controller (yellow cord) and make sure the emergency switch is not on.



Raise Decelinator by pushing the toggle switch up.



Raise the Decelinator until the lift rams can no longer raise the zip cords up in the air.

Raise the Decelinator™ back up into the full, operating position until you can no longer raise the hydraulic lift rams with the weight attached.





You can also do a weight test with an operator and additional sand bags to equal 250 lbs. Walk back from the line to apply tension on the cable.

NOTE: Cable tension will increase with weight applied and is a normal occurrence for operation.

With either a person and sandbags (a combined weight of 250 lbs.) or just sandbags at 250 lbs., raise the Decelinator™ to test the cable tension and ensure the cable clamp is secure.

Make sure that when the Decelinator™ is raised with a person attached that their feet are at least 12 inches off the landing surface. If not, adjust the lanyards to bring the person's feet off the ground. If this still doesn't resolve the issue, the landing surface is probably not level and will not be suitable for safe operation.

Inspect the Decelinator's™ springs for proper operation. Make sure to have two operators during the testing process. Visually inspect the springs' reaction to the test weight. Make sure that the Decelinator™ raises and lowers slowly and freely when using the lift controller.

This operation must be performed prior to the first zip of each day. This test procedure is also required after replacing the Extreme Engineering zip cords on the Fly Wire™ prior to allowing anyone to zipline, including you, the operator. As a good measure of safety, you should periodically recheck the Fly Wire™ operation a couple of times throughout the day's operation of the zipline.



CAUTION: DO NOT OPERATE if the participants' feet are less than 12 inches off the ground. The zip cords must allow enough clearance for zipliners when ending the zip ride. Failure to allow enough clearance can cause serious bodily injury.





NOTE: Increased tension will display on the gauges when weight is applied to the zip cords. This is a normal occurrence during safe operation. The tension gauges should return between 1,000 to 1,300 lbs once a zipliner is removed from the zip cord.

After testing the zip cords successfully, the Decelinator™ is ready for operation. Lower the Decelinator™ back to the ground and remove the test weight.

Check that the Decelinator™ has not moved from the use of the test bags. If the Decelinator™ has moved, you must add additional counterweight to stop movement. If the landing area is grass or a soft surface, always secure the Decelinator™ with tent stakes in addition to the counterweight. If the option is available, it is always the best to also use tent stakes in addition to the counterweight. Follow the counterweight diagram provided with this manual (see page 58).



CAUTION: DO NOT use the Fly Wire™ if the Decelinator™ has moved during testing. Make sure to include the correct amount of counterweight and, when necessary, tent stakes if using a lawn or soft operating surface.

Walk up and down the zipline platform to check for signs of movement in the trailer and/or platform. There should not be any major signs of movement when walking up and down the zipline's staircase. **DO NOT** zipline down the platform when inspecting for movement.



CAUTION: If this step does not exhibit proper operation, **DO NOT Proceed, DO NOT use the Fly Wire™™. Contact Extreme Engineering for assistance at 916-663-1560.**



CAUTION: DO NOT unlock the cable clamp during operation or before lowering the Fly Wire™ platform. Unlocking the cable clamp can tangle the winch spool and cause serious damage to your Decelinator™ and/or Fly Wire™. Never operate the Fly Wire™ with the cable clamp unlocked.



CAUTION: ENSURE that during operation of the zipline that operators do not come into close contact with the winch handle, accidentally putting the winch into "free-spool" mode. This can cause serious injury to the Fly Wire™ and a potential catastrophic failure. You assume all risk and hold Extreme Engineering harmless from any injuries and/or death by failing to abide by the safety procedures in the manual.



CAUTION: ALWAYS remove the winch controllers before operation and once the appropriate tension is set on the zip cords.



4.10 Plugging in safety box/auto-locking door controller from the Fly Wire™ platform to the Decelinator™

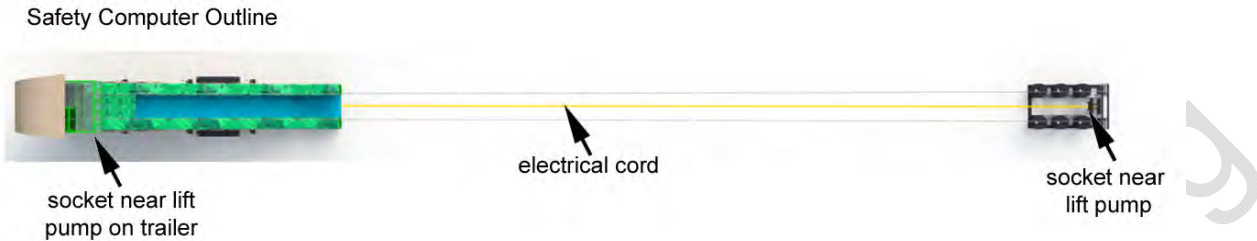

The socket on the trailer end is located on the driver's side of the trailer near the lift pump. The socket on the Decelinator™ is located in the center near the lift pump.

Socket Locations for power cord on auto-locking door

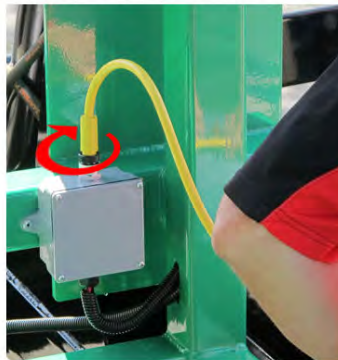

Socket location on Zippin Zone platform. Located on driver's side of trailer.

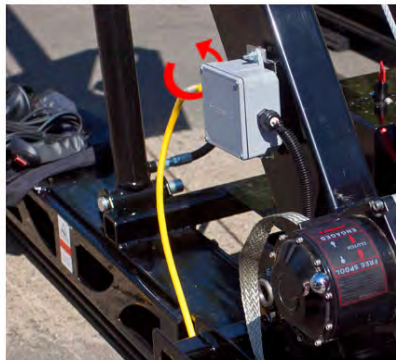

Socket location on Decelinator. Located on the driver's side of trailer.

Take the power cord and plug it into the computer socket on the Decelinator™. Run the power cord down the center of the zip cords and to the Fly Wire™ trailer. Plug the other end of the power cord into the socket located on the trailer.

Once the electrical cord is plugged in, ensure it rests on the ground between both zip cords. You can tuck the cord near the side of the Fly Wire™ and under the inflatable slide.



Test the auto-locking doors

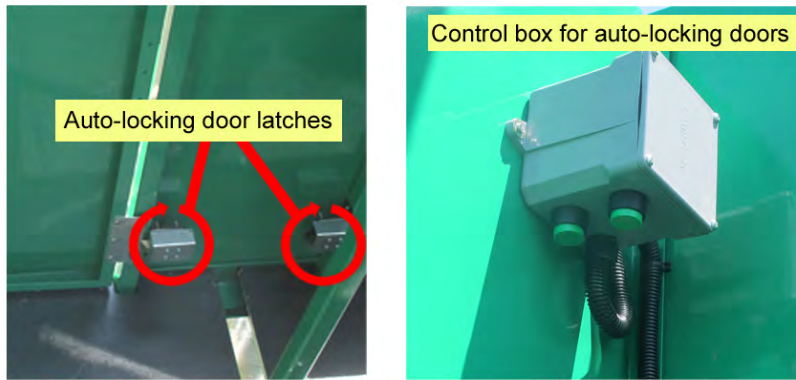

Walk up the Fly Wire™ and test each door latch by activating the control box buttons on top of the platform. Perform this test with the Decelinator™ in the up position. Visually inspect the door latch, ensuring they unlock once the control box's buttons are pushed. The doors should unlock with the buttons pushed and the Decelinator™ in the up position.

Lower the Decelinator™ (use a second operator for this step) and try to activate the door latches by pressing the buttons. The door latches should not unlock with the Decelinator™ in the down position.

****If the auto-locking doors work correctly, the Fly Wire™ and Decelinator™ are ready for operation.**



NOTE: The Decelinator™ has a safety box installed on the system that prevents the exit doors of the Fly Wire™ platform from unlocking when the Decelinator™ is in the down position. This safeguard eliminates any possibility of an operator error of pressing the open buttons on the exit doors before raising the Decelinator™. The doors remain locked, even if the buttons are pushed, until the Decelinator™ is fully raised.



CAUTION: DO NOT operate the Fly Wire™ without the safety box cord plugged into the Fly Wire™. Operating the Fly Wire™ without the safety computer plugged in can result in injury and/or death. You assume all risk and hold Extreme Engineering harmless from any injuries and/or death by failing to abide by the safety procedures in the manual.



CAUTION: DO NOT ride the Fly Wire™ before first using test weight. Riding the Fly Wire™ without first using test weight can result in serious injury and/or death. Extreme Engineering is not liable and is held harmless if you fail to abide by the testing procedure in this manual.





CAUTION: If the Fly Wire™ and/or Decelinator™ do not meet proper operational standards, **DO NOT proceed. DO NOT use the Fly Wire™ and/or Decelinator™.** Contact Extreme Engineering for assistance.

4.11. Test Zipline (You will need three operators for this step)



Scan QR code to watch harness video

Step 1. Attaching Zipline Harness

Zip Line Harness Overview



Before you zip, put on an Extreme Engineering Speed Harness™.



Attaching Zip Line Harness



Hold Harness above the waist with the gear loop facing in the front.



Click in the safety buckle located on the backside of the harness. Tighten the harness around the waist by pulling on the webbing.



Click the seatbelt buckles and tighten the leg loops around both legs. Make sure the loops are not twisted or tangled.



This is how the harness should look when placed on correctly. Inspect that the harness is snug.

There are two lanyards (one black and the other red).



NOTE: Please note that the red lanyard may vary in color. The black lanyard will always be the backup lanyard.



Standard adjustable buckle is designed to extend or bring in the length of the lanyard.

The lanyards lengths can be adjusted with the steel buckles. The buckles are designed to extend or shorten the length of the lanyards.



NOTE: The red or colored lanyard should be just long enough to attach the participant to the zipline pulley, at the top of the zipline tower, when the zipline pulley is attached to the zipline cable. We also offer other lanyard lengths for



shorter participants. The black lanyard, backup lanyard, should be at least 8” longer than the red or colored lanyard.

Attach both lanyards to the harness’s gear loop with a carabiner. Ensure that the carabiner is securely locked into the gear loop of the Speed Harness™. The red lanyard is the main lanyard used for ziplining and held onto when coming off the Fly Wire™ platform. The black lanyard is the safety backup.

Attaching Lanyards

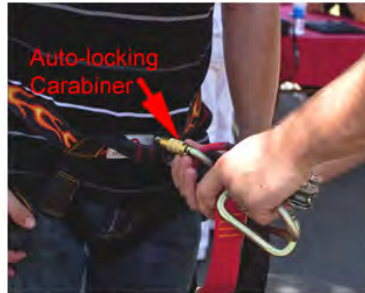

Attach both of the lanyards with a carabiner to the gear loop on the Speed Harness. Check that the carabiner is locked through the gear loop.



The red lanyard faces forward and is used as the main lanyard for zip lining. The black lanyard is the safety backup. Some minor adjustment may be needed to adjust the length.



Attach a carabiner from the red lanyard to the main zip line pulley attachment. Then attach the black lanyard to the backup zip line pulley attachment.
NOTE: The arrow engraved on the zip line pulley should be pointing away from the zip liner and towards the Decelerator when attached to the zip cord.

Attach the red or lanyard to the zipline pulley’s main attachment and the black lanyard to the backup attachment with carabiners. Check that the carabiners are securely locked into the zipline pulley.



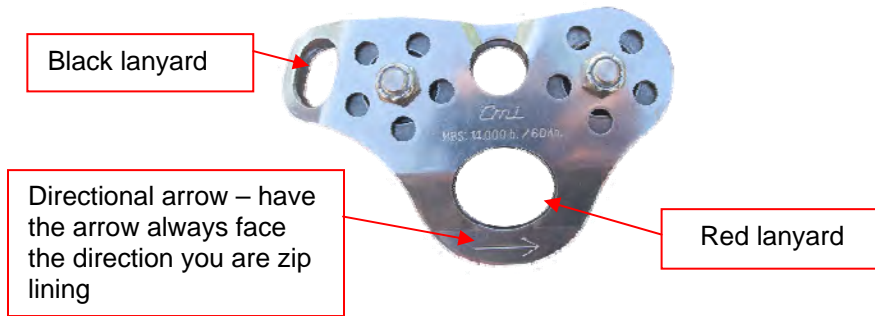

Step 2. Walk up Fly Wire™ platform once fastened to a zipline harness.

The participant will walk up the spiral staircase and the second operator, at the top of the platform, will secure participant safely to the handrail and then to the zip cord prior to riding.

Operator Safety Lanyard



Connection for operator safety lanyard.



Wear a Speed Harness and use the lanyard (black) to connect to the center beam, between the zip cords. Always be securely attached with a safety lanyard during operation.

The second operator will need to be securely fastened to the rail on the Fly Wire™ platform, at all times, using a Speed Harness™ or safety harness and lanyard that is attached to the safety rail with a carabiner.

The second operator will first connect the zipliner to the safety rail with the black lanyard and carabiner. After the zipliner is connected to the safety rail, the operator will then connect the red lanyard from the zipliner to the zipline pulley, which is fitted to the zip cord.



Securing Participant to Zip Cord



Connect the participant to the hand rail with the black lanyard.



Slide the zip line pulley over the zip cord and attach the red lanyard to the main zip line attachment.



Take the black lanyard from the handrail and then connect it to the backup zip line pulley attachment. Make sure the zip cord is through the carabiner.

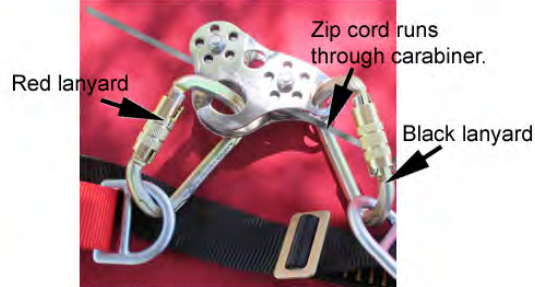

This is the correct way the zip line pulley connection should look when attached to the zip cord. Check that the carabiners are locked.

Once the zipliner is securely fastened to the rail with the black lanyard, take the zipline pulley and slide it over the zip cord. Attach the red lanyard from the zipliner's harness to the zipline pulley with a carabiner. Remove the black lanyard from the rail and click the black lanyard behind the zipline pulley and over the zip cord with the other carabiner. This is to serve as a backup device and provide redundancy for the zipline pulley.



Ensure that the directional arrow on the zipline pulley is facing forward and pointing toward the Decelinator™.



NOTE: Make sure that the black lanyard (backup lanyard) is used to fasten the zipliner to the platform's rail, not the red lanyard (zipline pulley lanyard).



NOTE: The red lanyard may vary in color. The colored lanyard will always be the zipline lanyard and the black will be the backup.



CAUTION: ALWAYS keep everyone (operators and participants) at the top of the platform secured to the safety bars with the lanyards and carabiners.

Check that the carabiners are securely fastened to the harness, zipline pulley, and zip cord. Once the Decelinator™ is raised in the air the exit doors can be opened by pressing the buttons. Tell the zipliner: **DO NOT JUMP OR RUN THROUGH THE DOOR!**



Press button to unlock door. Tell the participant to gently swing door open and to prepare to zip line.



Once the door is open ask the participant to walk off the platform to zip line. **DO NOT** allow the participants to jump or run through the doors!



NOTE: The buttons which unlock the exit doors are purposely distanced far enough from the zipliner so that they can't be pressed by anyone other than the operator. The doors will not unlock unless the Decelinator™ is raised in the operating position.

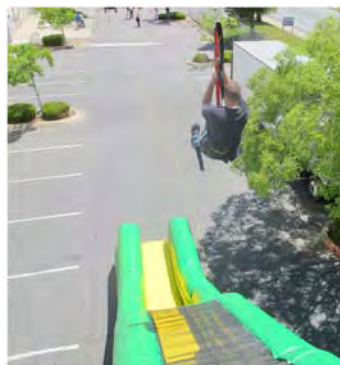

Repeat steps one and two on the second zipline cord.





CAUTION: ENSURE that the first operator gives the signal that the Decelinator™ is raised and ready for ziplining. The doors will not open without Decelinator™ fully raised in the up position.



CAUTION: DO NOT allow participants to run or jump off platform when ziplining. Allowing participants to run or jump off platform can cause serious bodily injury and/or damage to the Fly Wire™™.

5.0. Prepare To Operate the Fly Wire™

These final steps will make the Fly Wire™ ready for participants.

It is highly recommended to have a crowd control barrier around the Fly Wire™ entrance and Decelinator™. You might use stanchions to keep those waiting to zip out of the landing area and provide a place for participants to line up while waiting, being harnessed and cued toward the Fly Wire™ platform entrance.



NOTE: Fencing requirements may vary depending on the rules in your region. Refer to your state or country's crowd control requirements. Abide by any regulations and/or recommendations on fencing requirements from your local official.

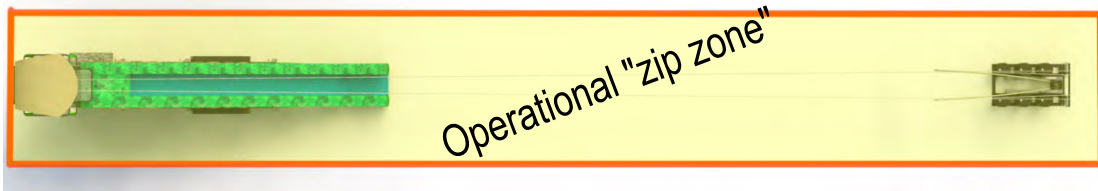

We recommend having a six to eight foot clearance in front and around the complete operational setup of the Fly Wire™ to keep people clear from participants. This is what we call the “zip zone” that can be used to harness, de-harness and allow the participants to zip in a safe area.

Set up a cashbox and/or ticket booth near the crowd control ropes at one side of the Fly Wire™.

The cashbox and/or ticket booth should be adjacent to a “harness area,” so one operator can both collect money and harness participants. If you use tokens or tickets, the operator will still need to collect these. (See the Operating Techniques section in the manual).

Establish your method of entrance control. This includes how tickets are used, supervising the entrance point to the line, etc. Be sure to test out the entrance control and method of communication to both the operator on the zipline platform and Decelinator™.





CAUTION: Before using the Fly Wire™ make sure your operators are clear on procedures. Do not operate if they are not clear on procedures.

Make sure you are in compliance with any applicable rules and regulations at the site or event.

You should have a plan established for handling contingencies like medical or other emergencies, even though these are unlikely to occur. Make sure every member of your crew knows this information. Create an emergency exit strategy that the operational crew is familiarized with.

6.0. Banner Options

Always set up your banners prior to raising the Fly Wire™.

If you decide to use a banner on the Fly Wire™ platform, make sure the banner is made of mesh material so wind can pass through during outdoor use. **DO NOT** use a large, solid vinyl banner. This can cause a sailing effect and move the Fly Wire™. Placing grommets on the perimeter of the banners allow the use of zip-ties to the steel zipline platform.



CAUTION: DO NOT self tap or screw a banner directly into the steel frame of the Fly Wire™. Also **DO NOT** modify, weld or bolt in any type of off-shelf banner bracket and/or flag poles into the Fly Wire™ substructure. Failure to comply will void the warranty and potentially cause damage to the Fly Wire™.



CAUTION: DO NOT set up banners if high winds are present during operation. Even if banners are made to breathe, do not operate in high wind conditions. Doing so may result in a sailing effect.



7.0. Harness/Zipline Pulley setup instructions

See diagram below to properly install the Speed Harness™

Attaching Zip Line Harness



Hold Harness above the waist with the gear loop facing in the front.



Click in the safety buckle located on the backside of the harness. Tighten the harness around the waist by pulling on the webbing.



Click the seatbelt buckles and tighten the leg loops around both legs. Make sure the loops are not twisted or tangled.



This is how the harness should look when placed on correctly. Inspect that the harness is snug.



See diagram below to properly install zipline pulley.

Attaching Lanyards

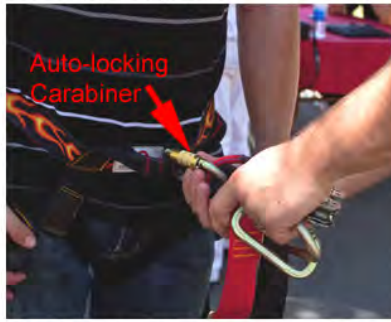

Attach both of the lanyards with a carabiner to the gear loop on the Speed Harness. Check that the carabiner is locked through the gear loop.



The red lanyard faces forward and is used as the main lanyard for zip lining. The black lanyard is the safety backup. Some minor adjustment may be needed to adjust the length.



Attach a carabiner from the red lanyard to the main zip line pulley attachment. Then attach the black lanyard to the backup zip line pulley attachment.
NOTE: The arrow engraved on the zip line pulley should be pointing away from the zip liner and towards the Decelerator when attached to the zip cord.

Securing Participant to Zip Cord



Connect the participant to the hand rail with the black lanyard.



Slide the zip line pulley over the zip cord and attach the red lanyard to the main zip line attachment.



Take the black lanyard from the handrail and then connect it to the backup zip line pulley attachment. Make sure the zip cord is through the carabiner.

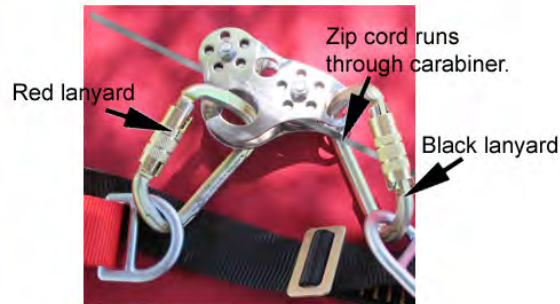

This is the correct way the zip line pulley connection should look when attached to the zip cord. Check that the carabiners are locked.

The Fly Wire™ tower has safety handrails mounted around the crow's nest of the platform. These handrails are designed to allow the participant to be safely attached to the tower at all times before ziplining. The operator will also be attached to the tower at all times when connecting zipliners. The process in the images above explains that the participant is connected at all times to either the handrail or zipline pulley/cable. This is a simple and easy process that will ensure the safety of every participant when following these steps.



CAUTION: DO NOT use aftermarket harnesses and/or pulleys. Use only OEM equipment from Extreme Engineering. Using aftermarket harnesses and/or pulleys will void your warranty and potentially cause severe damage to the Fly Wire™. You can also cause bodily injury and/or death by not using OEM equipment from Extreme Engineering. Extreme Engineering is not liable and is held harmless if you fail to abide by the operating procedure in this manual.



8.0. Operating the Fly Wire™



CAUTION: Read all instructions before operating the mobile Fly Wire™.



CAUTION: Ziplining is a physical activity and all possible care should be taken to ensure the safety of the zipliners, spectators and operators. Always operate the Fly Wire™ according to the procedures described here.

8.1. Operating techniques

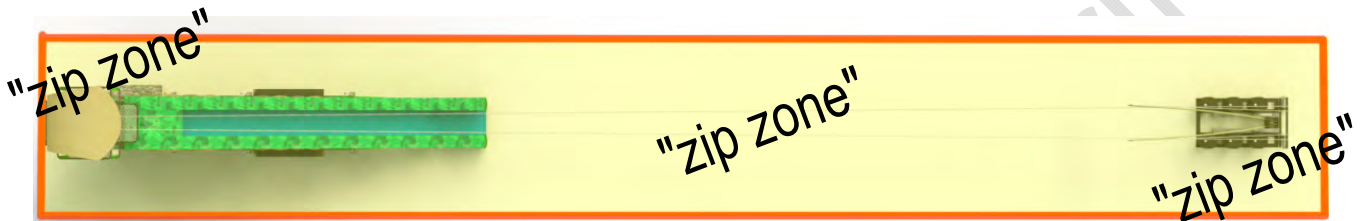

Make sure to keep the landing area clear of spectators. It is recommended to have at least six to eight feet clearance in front and around the complete setup of the Fly Wire™. Make sure to have plenty of clearance around the Decelinator™. This is called the “zip zone.”

Use four operators for optimal performance (highly recommended for high-traffic events, such as fairs and festivals)

4 Operator Setup - Most Optimal For High Traffic Use

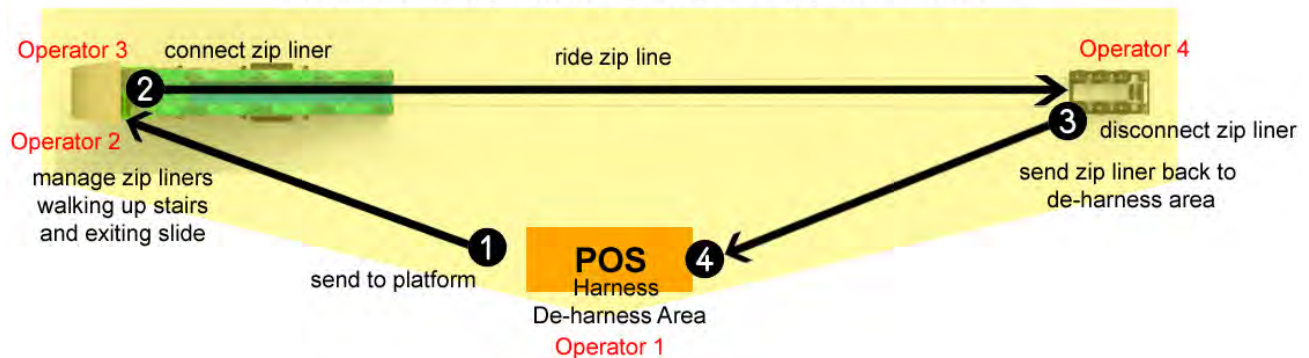

Operator 1 (optional two crew members can be used for these responsibilities)

- Takes money (or tickets, or tokens, if money is taken elsewhere)
- Helps the participants complete release forms (may be necessary for your insurance carrier)
- Harnesses the participants and provide them with the zipline pulley
- De-harnesses the participants
- Sends participants to **Operator 2** once harnessed and have the zipline pulley



- Assists participants who finished the ride to the exit of the “zip zone” area

Operator 2

- Supervises participants walking up the zipline platform as well as to the top of the platform
- Manages the amount of participants allowed on the spiral staircase at any given time.
- Supervises the participants who decide to come down the slide
- If participant comes down the slide, **Operator 2** will send them back to **Operator 1** to be de-harnessed

Operator 3

- Supervises participants walking up the zipline platform as well as to the top of the platform
- Advises participants (acts as the coach)
- Solves participant problems or fear with zipping
- Sends patrons down the inflatable slide if they are too scared to zip (optional)
- Secures the participants to the platform and to the zip cord when the Fly Wire™ is ready for ziplining
- Presses the unlock buttons to allow participants to walk through exit doors of the Fly Wire™ platform
- Communicates with **Operator 4** at the end of the Decelinator™
 - **NOTE:** Extreme Engineering recommends walkie-talkies for communication between the Fly Wire™ platform and the Decelinator™

Operator 4

- Lowers the participants to the ground by lowering the Decelinator™
- Unhooks the participants from the Decelinator™
- Sends participants back to **Operator 1** to be de-harnessed
- Communicates with **Operator 3** at the top of the Fly Wire™
 - **NOTE:** Extreme Engineering recommends walkie-talkies for communication between the Fly Wire™ platform and the Decelinator™



Minimum of three operators recommended

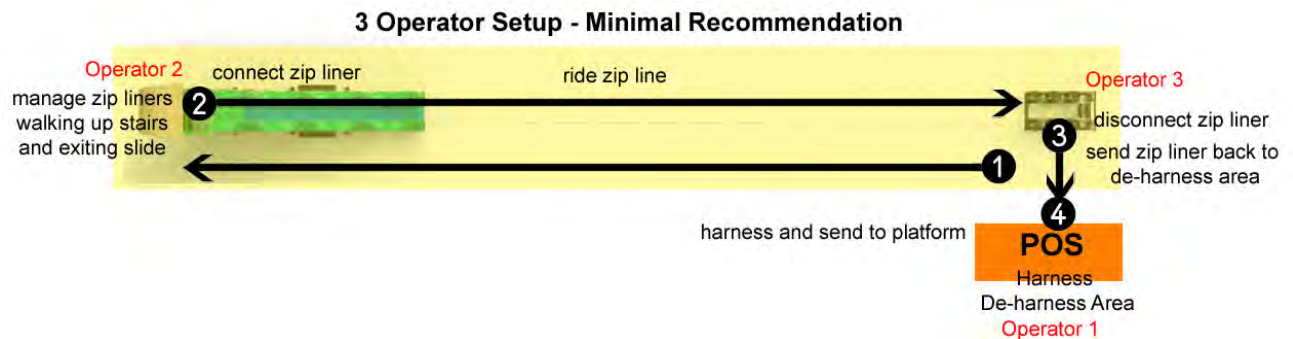

Operator 1 (optional two crew members can be used for these responsibilities)

- Takes money (or tickets, or tokens, if money is taken elsewhere)
- Helps the participants complete release forms (may be necessary for your insurance carrier)
- Harnesses the participants and provides them with the zipline pulley
- Sends participants to **Fly Wire™** once harnessed and have the zipline pulley
- Assists participants who finished the ride to the exit of the “zip zone” area
- De-harnesses the participants

Operator 2

- Supervises participants walking up the zipline platform as well as to the top of the platform
- Advises participants (acts as the coach)
- Solves participant problems or fear with zipping
- Sends patrons down the inflatable slide if they are too scared to zip (optional)
- Secures the participants to the platform and to the zip cord when the Fly Wire™ is ready for ziplining
- Presses the unlock buttons to allow participants to walk through exit doors of the Fly Wire™ platform
- If participant comes down the slide, **Operator 2** will tell them to go back to **Operator 1** to be de-harnessed
- Supervises participants walking up to the zipline platform as well as to the top of the platform
- Manages the amount of participants allowed on the spiral staircase at any given time
- Supervises the participants who decide to come down the slide
- Communicates with **Operator 3** at the end of the Decelinator™



- **NOTE:** Extreme Engineering recommends walkie-talkies for communication between the Fly Wire™ platform and the Decelinator™

Operator 3

- Lowers the participants to the ground by lowering the Decelinator™
- Unhooks the participants from the Decelinator™
- Sends participants back to **Operator 1** to be de-harnessed
- Communicates with **Operator 2** at the top of the Fly Wire™
 - **NOTE:** Extreme Engineering recommends walkie-talkies for communication between the Fly Wire™ platform and the Decelinator™

When the Fly Wire™ is not in use, you must keep the entrance of the zipline platform closed and the Decelinator™ in the down position. Make sure that the exit doors are locked at the top of the zipline's platform.

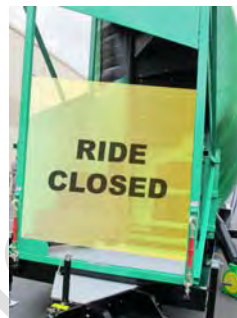

NOTE: It may be of value for you to purchase a “closed” sign to place in front of the Fly Wire™s™ platform entrance. Call for details and availability at 916-663-1560 or visit our online store at www.extremeengineering.com



NOTE: As a safety precaution, on top of the platform the exit doors will automatically lock if the Decelinator™ is not in the up position. This safety precaution prevents potential injuries and also ensures proper operation of the zipline.



NOTE: It is highly recommended that the operator controlling the Decelinator™ still give a “thumbs up” or some other cue to the second operator at the top of the Fly Wire™ platform once the Decelinator™ is in the up/operational position.



Walkie-Talkies are suggested for optimal communication.

Emergency Evacuation Plan

In case of an emergency below is a diagram on the exit routes for both the operators and participants on the Fly Wire™.

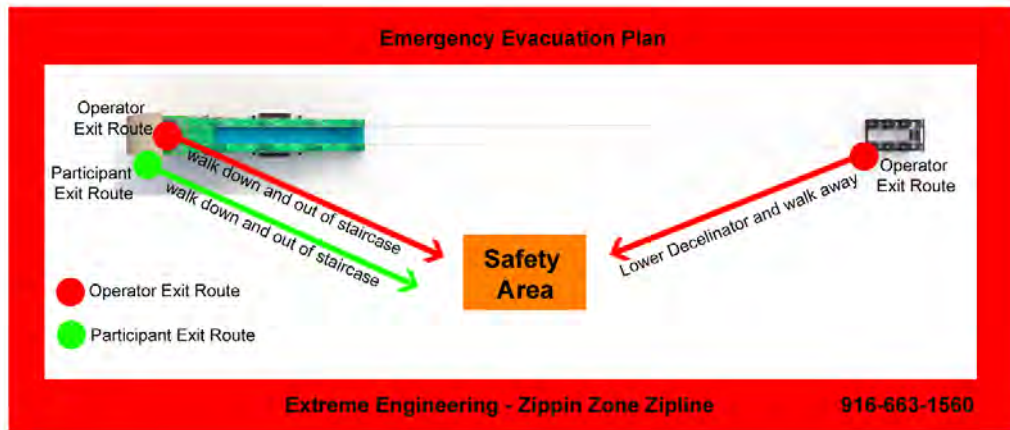

Operator exit routes. The operator located at the end of the zipline (who controls the Decelerator™) should safely lower the Decelerator™ to the ground, unplug the lift controller, walk away from the zipline and to the dedicated safety area.

The operator at the top of the Fly Wire™ platform should first ask the participants who are in the staircase to turn around, slowly walk down the staircase and exit to the dedicated safety area. If there are participants connected to the zipline cords at the top of the platform, safely disconnect them from the zip cords and guide them towards the staircase. Instruct the participants to walk safely down the staircase, exit the tower and head towards the dedicated safety area.

Participant exit routes. Participants should follow instructions given to them from the operators. The participants who are in the Fly Wire™ tower will walk back down the staircase and towards the dedicated safety area. All other participants will be asked to stay clear and way from the zipline area.





To ensure maximum safety and provide easy and quick setup for ziplining, use Extreme Engineering's Speed Harnesses™ and zipline pulleys during your events. They increase your cycle time, are the only compatible zipline gear with the Fly Wire™ and are safer to put on.



CAUTION: DO NOT use aftermarket harnesses or zipline pulleys on the Fly Wire™. For correct and safe operation, **YOU MUST** only use Extreme Engineering Speed Harnesses™ and zipline pulleys. Using aftermarket harnesses or zipline pulleys can result in serious injury and/or death. You assume all risk and hold Extreme Engineering harmless by failing to abide by the safety rules in this manual and/or fail to use OEM Extreme Engineering parts.

8.2. Safety Rules For the Operator

- ✓ Don't climb on the outside of the zipline platform or its supports.
- ✓ Don't stand on top of the zipline platform.
- ✓ Don't stand underneath the zip cords while ziplining is in progress.
- ✓ Don't leave the mobile Fly Wire™ unattended while ziplining is in progress.
- ✓ If you must leave the Fly Wire™ unattended (while not in use), make sure that the entrance of the Fly Wire™ is not accessible, the zipline platform's gate is locked and the Decelinator™ is in the up position. If this becomes too difficult, the best solution is to keep one crew member at the Fly Wire™ at all times.
- ✓ Using the optional "closed" sign is highly recommended, to prevent unauthorized entrance into the zipline platform and on the staircase.
- ✓ Don't let a participant put on or take off a harness. The operator must always do this.
- ✓ Don't touch any zipline pulleys or cords within the zipline structure while the Decelinator™ is operating. If you must handle the zip cords while a zip is in progress, it should only be the zip cords on the start end side of the zipline, and as described in the special situations section below. (Section 7.3)
- ✓ If an inflatable slide is equipped with the Fly Wire™, do not stand on top of the slide or deflate the slide if it is attached to the Fly Wire™ during use.
- ✓ If you do not use the optional slide, keep the end cap door closed and securely locked.





CAUTION: Don't wear any loose clothing, such as scarves, neckties, etc., while operating or inspecting the ride, to prevent the possibility of becoming entangled in the ride's moving parts.

8.3. Safety Rules For Zipliners

It's a good idea to make participants aware of some simple rules when participating on the Fly Wire™. We suggest you reproduce these rules as a poster or handout for the participant (and his or her parents) to read. The following page is ready to photocopy, if you wish. You may reproduce these safety rules on a poster or freestanding sign of your choice. If you wish to purchase a safety sign please contact Extreme Engineering at 916-663-1560 or visit our online store at www.extremeengineering.com for details.



Safety Rules

Fly Wire™ Zipline

ZIPLINER RECOMMENDATIONS

- ✓ Must weigh 45 lbs minimum and be at least 40" tall, 250 lbs maximum to wear the harness. Two riders may go at the same time if both weights are no more than 250 lbs each.
- ✓ Zipliner must fit in the harness to be allowed to zip. Empty your pockets of loose items.
- ✓ Zipliner must not have any health conditions, broken bones, disabilities and/or be pregnant.

BEFORE YOUR ZIP STARTS

- ✓ After being hooked into the harness, stay in the harness area. Wait until the operator instructs you to go to the zipline platform entrance.
- ✓ Don't run up the zip line platform. Walk slowly up the stairs using two hands on the railing.

DURING YOUR ZIP

- ✓ Wait at the top of the zipline platform and follow the operator's instructions.
- ✓ Once you are securely fastened to the zipline cord you may exit the platform.
- ✓ Do not try to turn upside down or spin during your zipline experience.
- ✓ Gently step through the door and off the platform, **DO NOT JUMP OR RUN.**
- ✓ Have fun and scream!

DURING YOUR DESCENT

- ✓ Once you reach the end of the zipline, wait for the operator to lower you to the ground.
- ✓ Once your feet reach the ground, please stand and wait to be disconnected from the zipline.
- ✓ Do not remove your harness. Wait for the operator.

AT THE END OF YOUR ZIP

- ✓ After your zip is complete, wait for the operator to unhook you.
- ✓ Once you have been unhooked, and the harness has been removed by an operator, please slowly exit the ride. **DO NOT** try to remove the harness yourself.



8.4. Special Zipline Situations

The vast majority of ziplines take place without any difficulty or interruption, but sometimes a problem can occur. Here's what to do.

Participant frozen at top of the zipline platform

- Ask the zipliner to stay calm.
- (Optional) If an inflatable slide is equipped, ask the participant to go down the slide.



NOTE: The optional slide is the best way to handle scared patrons and improve cycle times. If your Fly Wire™ doesn't have a slide, refer to the next step below:

- Direct the other zipliners to move to the side of the platform, providing enough room for the scared participant to walk back down the platform and to the ground.
- Instruct the scared participant to use both hands on the railing and walk slowly down the platform. If the participant is too scared to walk down alone, ask the second operator to assist in helping the participant down the platform. **DO NOT** leave the platform unattended. Never leave patrons at the top of the platform.
- When the scared participant reaches the ground, have the second operator remove the harness and ask them to walk away from the “zip zone.”



NOTE: You shouldn't encourage a participant to zip if they do not want to.

Participant reports discomfort with harness

- Ask the participant to stay calm. Ask if the participant is comfortable with allowing you to adjust the harness before zipping. If so, adjust the harness to the participant's comfort level and ensure the harness is still securely fastened. Resume with connecting the participant on the zipline cord.
- If a zipliner is unable to resume for whatever reason, unhook and send the climber back down the zipline platform and out of the “zip zone” area.
- If a participant gets stuck on the zipline the backup lanyard may be too short, causing them to stop prematurely down the zipline. Grab onto the red (main) lanyard and pull down, forcing the black lanyard to expand and lower the zipliner.



Participant is intentionally reckless

- Ask the participant to take it easy. Choose one of the following options if he or she persists:
 - a. If you **DO NOT** believe the reckless participant and/or other participants would be endangered, tell the reckless participant to zipline now;

or
 - b. If you believe other participants might be endangered, tell the reckless participant to freeze at their position, and ask the other participants to move aside, making room for the reckless participant to walk back down the zipline platform and out of the “zip zone” area. If you need assistance, ask the second operator to guide the reckless participant out of the Fly Wire™ and safely away from the product.



NOTE: Feel free to call 911 if this is an emergency situation and the reckless participant is endangering others.

- Escort the reckless participant back to the harness station and out of the "zip zone" area. Remove the harness and ask the participant to leave the area.

9.0. End of Event Takedown



CAUTION: For your safety, read all instructions before taking down mobile Fly Wire™™.



CAUTION: Keep the area clear of people, cars, etc., during all steps of the takedown.

Clear the area of items used in operating the Fly Wire™, including stanchions, crowd control barriers, etc.

Clear the area of people, left over debris and/or cars.

9.1. Lower the Decelinator™



CAUTION: Keep the area clear of people while lowering the Fly Wire™ and Decelinator™. Also make sure there is nothing resting on the trailer base frame that might prevent the Fly Wire™ from completely lowering onto the trailer base (optional inflatable slide is the only item allowed to rest on the trailer base).



Lowering Decelerator



Plug in the Decelerator's lift controller (yellow cord) and make sure the emergency switch is not on.



Lower the Decelerator by pushing the toggle switch down.



Lower the Decelerator until the lift rams can no longer lower the the Decelerator to the platform. DO NOT remove zip cords before lowering!

Ensure that the exit doors on top of the zipline platform are closed and locked.

Ensure that the exit gate on top of the zipline platform is securely locked. Check that the locking mechanism has engaged correctly and that the gate is fully locked and will not open. Remove any additional hardware from the top of the platform (harnesses, zipline pulleys, etc). Remove the bimini assembly if it is attached to the zipline tower. Store loose items and the bimini assembly away from the zipline platform.



Remove turn buckles from Fly Wire™ platform.

Loosen the turn buckles on the Fly Wire™ platform and remove both of the turn buckles from the trailer.

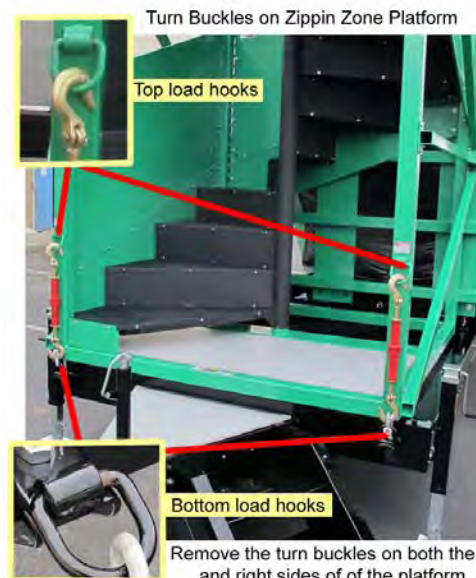

Turn buckle can be adjusted by twisting.

Remove additional staircase from trailer.

Remove additional staircase



Unhook the staircase into the notches located on the side of the tongue of the trailer.

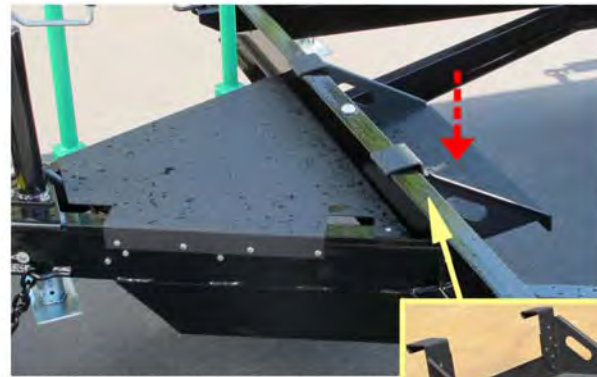

Store the additional staircase behind the tongue of the trailer by hooking the staircase on the steel trailer frame.

Attach the hydraulic lift pump controller. Insert the metal plug attached to the controller to the controller socket attached to the pan of the trailer base. The socket is found at the side of the trailer, in front of the fenders, near the tongue. Raise the protective cover off the socket and fully insert the controller plug.





Locate the lift pump between the two lift rams, towards the tongue of the trailer.



Raise the protective cover off the socket to attach the lift controller.



Make sure to align the notch on the plug with the socket to successfully insert the controller.



Connect controller.

Lower the Fly Wire™ with the controller. Press down on the controller toggle switch to lower the Fly Wire™. While the Fly Wire™ platform is lowering, listen for any abnormal sounds. Watch the Fly Wire™ as it lowers to ensure it continues to lower and is lowering at its normal speed.



NOTE: If you have your inflatable slide attached, refer to the installation of slide portion of this manual to safely remove the slide. Reverse steps for proper removal of inflatable. Ensure that the inflatable is rolled and safely stored away from the Fly Wire™. Always use the steel ram stop when partly lowering/raising the Fly Wire™ tower.



Lower the Fly Wire™ tower until it is fully in the down position and resting on the trailer. Watch the Fly Wire™ tower and base frame to ensure that it will rest firmly on the trailer when approaching and completing its final lowering position.



Lower the Fly Wire™ to the horizontal position in one *continuous* motion. Try to avoid pressing the DOWN button multiple times during the lowering cycle. **DO NOT** continue to force the Fly Wire™ any further than its complete lowering position. This can cause damage to the frame and trailer.



NOTE: If you have the optional slide, ensure that the slide is deflated first and the Fly Wire™ tower doesn't pinch the slide between the trailer and the tower.

Stop lowering the Fly Wire™ platform once the platform rests firmly on the trailer.

Remove the controller from the lift pump and safely store.



CAUTION: DO NOT lower the zipline platform with a person inside or on top of the tower. Lowering the zipline platform with a person inside or on top of the tower can cause serious injury and/or death. You assume all risk and hold Extreme Engineering harmless by failing to follow the safety procedure in this manual.



CAUTION: NEVER hold the down button for longer than two seconds after the tower has rested onto the base frame. Holding the button longer than two seconds will damage the base frame, tower frame and upper hinge lift arms.

If the Fly Wire™ is lowering slower than normal, this could be a sign of a weak charge on the battery.

In an emergency, to lower the Fly Wire™ with a weak battery, the battery can be hooked up to the tow vehicle battery temporarily to complete the lowering cycle. Once the Fly Wire™ has been lowered successfully, disconnect the jumper cables.

If the Fly Wire™ had to be raised with the help of the tow vehicle, it will also require help when lowering. The default operation of the pump is to raise the Fly Wire™. When battery



power drops below a sufficient level, the direction control module will not engage when the pump is running. The direction control module reverses the flow direction of the hydraulic oil and this causes the Fly Wire™ to lower. If the direction control module does not engage, the pump will only attempt to lift the Fly Wire™ further. It will not lower.

It is possible that there is sufficient charge to raise the Fly Wire™ during the lift cycle, but that drains the battery enough so that it won't lower due to the inability to engage the direction control module. In both of these cases, you will have to connect the tow vehicle battery to the mobile Fly Wire™ battery in order to lower the Fly Wire™. This is the same for the battery located on the Decelinator™.

Attaching the battery is the same as with jumping another vehicle that won't start. Attach the positive jumper cable lead to the positive post on the mobile Fly Wire™ battery. Attach the negative lead to the negative post on the mobile Fly Wire™ battery. Make sure that the opposite ends of the negative and positive leads on the jumper cables **DO NOT** touch each other or any portion of metal on either the mobile Fly Wire™ or the tow vehicle inadvertently. Attach the positive lead to the tow vehicle's positive battery post. Lastly, attach the remaining negative lead to a good, solid metal ground point on the tow vehicle. Start the tow vehicle and then lower the Fly Wire™ using the controller. Carefully disconnect the leads by first disconnecting the negative cable from the vehicle ground point and the positive battery post on the tow vehicle. Remove the negative lead from the mobile Fly Wire™ battery and then remove the positive lead from the battery.

Pack up any shims and wheel blocks and store them away from the Fly Wire™.



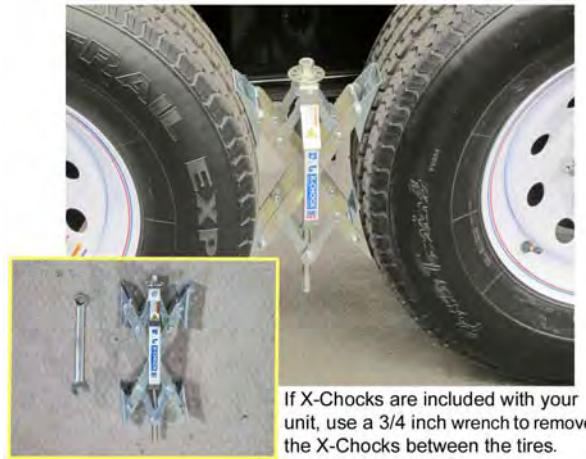

Lower the Decelinator™ unit and prepare for loading.

Lower the Decelinator™ toward the ground with the lift controller. Take the metal plug attached to the controller and place the plug into the controller socket located near the hydraulic pump on the Decelinator™. Lower the Decelinator™ toward the ground until it can no longer lower anymore.

Lowering Decelinator



Plug in the Decelinator's lift controller (yellow cord) and make sure the emergency switch is not on.



Lower the Decelinator by pushing the toggle switch down.



Lower the Decelinator until the lift rams can no longer lower the the Decelinator to the platform. DO NOT remove zip cords before lowering!



NOTE: If the controller is still plugged into the Decelinator™, simply lower the system then unplug the controller.



CAUTION: DO NOT tow away the mobile Fly Wire™ with without securing the Decelinator™ onto the trailer base.

Unplugging the computer socket from the Decelinator™ to the Fly Wire™ platform.

Unplug the power cord from the computer socket on the Decelinator™. Roll up the power cord down the center of the zip cords and to the Fly Wire™ trailer. Unplug the other end of the power cord into the socket located on the trailer. Safely store the power cord away from the Fly Wire™.

Safety Computer Outline

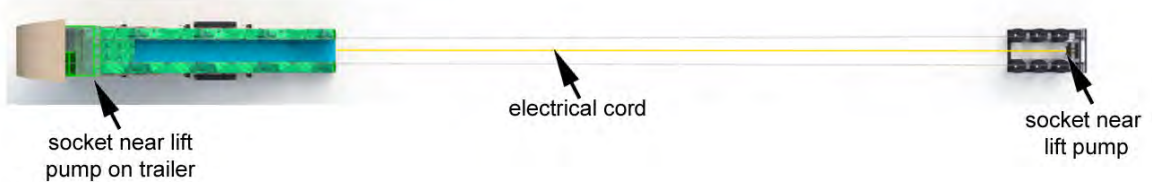

Socket Locations for power cord on auto-locking door

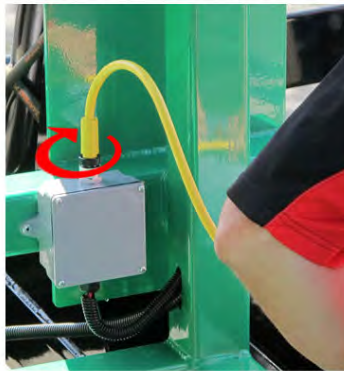

Socket location on Zippin Zone platform. Located on driver's side of trailer.

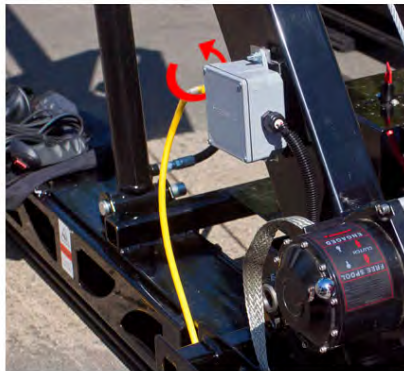

Socket location on Decelinator. Located on the driver's side of trailer.

Remove zip cords from the Fly Wire™ platform.



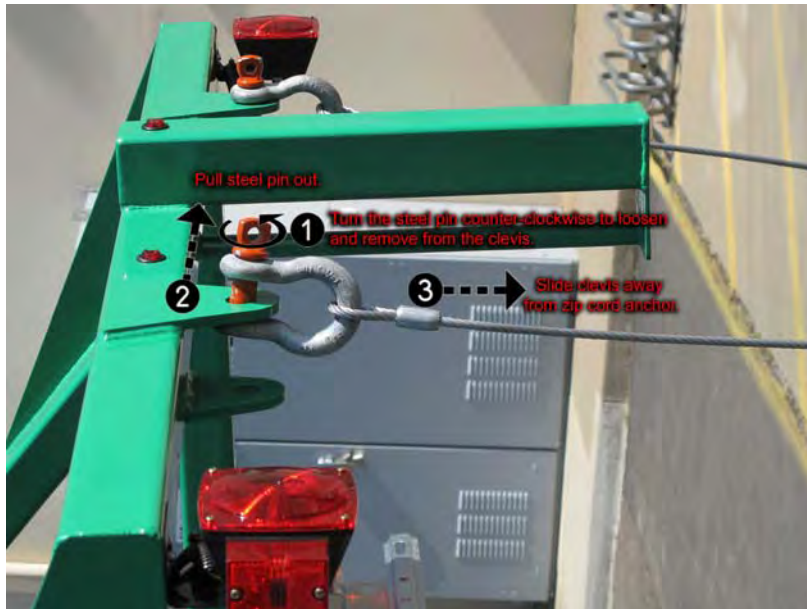

Remove the zip cords from the pulley guides.

Unlock the cable clamps and remove the zip cords from the pulley guides. Put the winches into the “free spool” position and plug in the winch controller. Bring in the slack on both of the winches. Make sure to not bunch all of the zip cords in the center of the winch. (See diagram below).





1
Unlock the cable clamp next to the gauge, releasing slack.



2
Activate the "Free Spool" option on the Winch by pulling the lever towards you or where it is indicated on the winch.



3
Locate the socket on the winches and align the winch controller's plug with the socket. Plug the controller into the socket.



4
Push the button down, "in" position, to bring in the slack and roll cable along the spool until you no longer can bring in the cable on the winch. Repeat on 2nd zip cord.

Make sure to not bunch all of the zip cords in the center of the winch when bringing the slack back onto the winch.

Spool nicely rolled onto winch with no bunching of cable.



CAUTION: Wear gloves to avoid causing bodily injury when handling the zip cords.

Remove zip cords from Decelinator™ and safely wind the zip cords with the sleeves onto the center of the Decelinator™ (see below).



Removing Zip Cords from Pulley Guides



There are pulley guides on the left and right side of the Decelinator to freely guide the zip cords to the Zippin Zone platform. This must be removed for safe storage of the Decelinator.

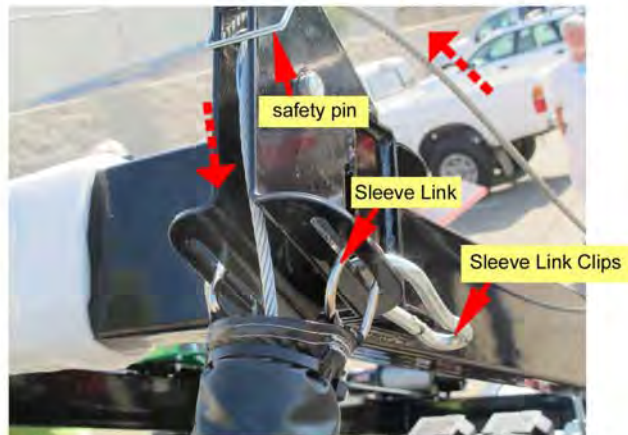

Pull the safety pin and remove the zip cords from the pulley. Place the safety pin back into place. Remove the sleeve link clips, and lock the safety pins back into place. Repeat this step for the 2nd line.

Storing Position



9.2. Prepare the Fly Wire™ For Transport and the Decelinator™ For Loading

Move the jacks and outriggers to their proper travel position.

Raise all of the jacks, including the outriggers, and place them all back into the towing position on the Fly Wire™ trailer. Turn the jacks counter-clockwise to raise the drop legs off of the ground (see diagram below).

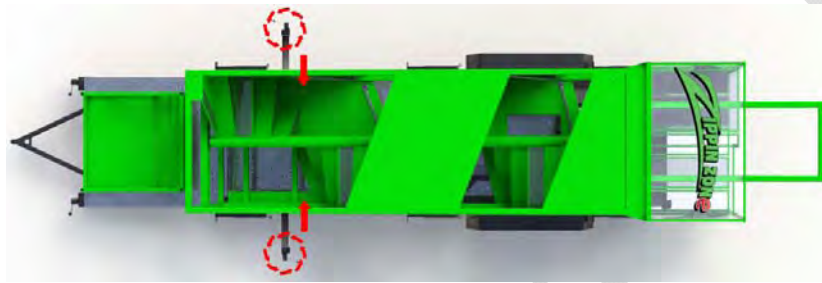

Setting outriggers into the towing position.



Crank jack handle counter-clockwise and pull release hook to raise drop leg back into the jack.



Ensure that the drop leg locks back into the jack.



Pull up the pop-pin to allow the outrigger to slide back towards the trailer.



Slide the outrigger towards the trailer until the pop-pin locks back into place.

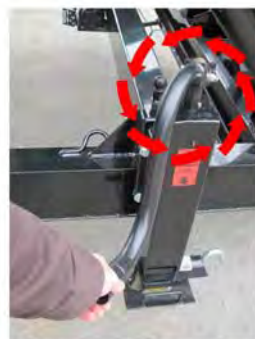

Turn jack handle counter-clockwise until you no longer can raise the jack.



Repeat step on other outrigger if necessary.





1 Locate all four stabilizing jacks.



2 Turn jack handle counter-clockwise to raise the jack leg off the ground.



3 Pull safety lock clip from drop leg pin.



4 Remove drop leg pin from drop leg.



5 Push drop leg up into jack and securely fasten the leg pin back into place.



6 Continue to raise the jack, counter-clockwise, until you no longer can bring up the drop leg.

Ensure that all wheels of the trailer are now firmly on the ground and the stabilizing jacks are completely raised. Check that each drop leg of the jacks is completely raised. Check that the pins are securely fastened and holding the drop legs into place.



CAUTION: DO NOT tow the Fly Wire™ with any stabilizing jacks in the down position. Ensure that all jacks are stored correctly in the tow position. Failure to do so will cause serious damage to the trailer.

Back the tow vehicle into position so that its towing ball is positioned under the mobile Fly Wire's™ trailer tongue. If you have a second operator, have him or her stand by the trailer to guide you into position. Position the tow vehicle's hitch as close as possible to the tongue of the trailer, with the trailer coupler as close to directly above the towing ball as possible.

Follow section 2 and 3 of this manual for attaching and towing the mobile Fly Wire™.



Back the Fly Wire™ toward the Decelinator™

Once the Fly Wire™ trailer is properly attached to the tow vehicle, back the Fly Wire™ near the Decelinator™ so the winch can be safely used to pull the Decelinator™ back onto the base of the trailer. Make sure that the Fly Wire™ is aligned with the Decelinator™ and not at an angle so it can easily be stored on the trailer.

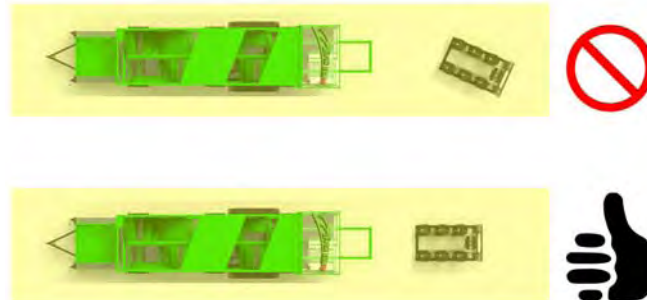

NOTE: DO NOT try to move the Decelinator™ onto the base of the trailer without using the winch.



CAUTION: DO NOT manually load the Decelinator™ onto the base of the trailer. Failure to use the winch may cause serious bodily injury and damage to the Fly Wire™.



CAUTION: ALWAYS have the safety chain connected from the Fly Wire™ trailer to the Decelinator™ in the towing position. Failure to do so can cause severe damage to both the Fly Wire™ and Decelinator™.



CAUTION: RAMPS MUST NOT BE ATTACHED when raising Fly Wire™ tower.

Partly raise the Fly Wire™ to give clearance to load the Decelinator™ onto the trailer.

Lower the steel ramps first, then partly raise the Fly Wire™ until it has enough space to load the Decelinator™. Do not disconnect the towing vehicle from the trailer. The towing vehicle will securely hold the trailer in place and also still be needed to tow the Fly Wire™ trailer. If clearance is still needed, raise the tower.





Once the tower is partly raised, put a steel ram stop under the platform. This is a safety precaution to prevent the tower from lowering back onto the trailer.



Raise the steel ram stop, bolted to the trailer, underneath the Zippin Zone platform. Lower the platform onto the ram stop.

Load the Decelinator™ onto the trailer. Plug in the winch's controller to release slack, pulling enough cable to connect to the Decelinator's™ load hook. Connect the Fly Wire's™ cable winch to the load hook on the Decelinator™ (see diagram below)



Storing Decelinator on trailer



Button can either bring in "IN" the cable slack or "OUT" release cable from winch.



Plug in the winch controller.



Free the spool on trailer's winch. Press the "out" button to release the cable slowly to the ground.



Connect the winch's hook to the front load hook on the Decelinator.



Turn the trailer's winch counter-clockwise to the "Engage" position. Hold the "IN" button on the controller to slowly bring the Decelinator onto the trailer's track.



Carefully bring the Decelinator onto the Zippin Zone's trailer by ensuring the Decelinator loads onto the track. Stop until you can no longer bring in the winch's slack and the Decelinator onto the track. Remove controller and safely store away.

Check that the winch is securely fastened to the load hook on the Decelinator™. Bring in the slack from the winch, gently pulling the Decelinator™ as far forward onto the Fly Wire's™ trailer as possible. Keep the winch in the "engaged" position and unplug the winch's controller.

Connect the safety chain from the trailer to the Decelinator's™ load hook. This is the same load hook that the winch's cable stays connected to. The safety chain is a backup precaution to prevent the Decelinator™ from moving or if the trailer winch's cable fails it will securely hold the Decelinator™ in place during transit.



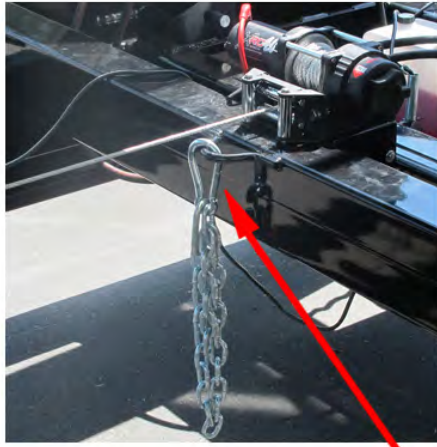

Safety Chain

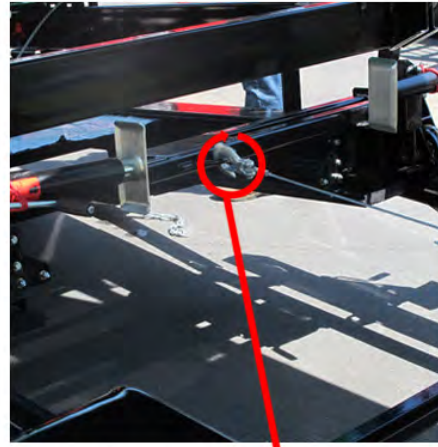

Decelinator Load Hook



NOTE: The load hook is located toward the front end of the Decelinator™ (opposite side of winches).



CAUTION: DO NOT leave the trailer's winch in the "engaged" position when you are done loading the Decelinator™ onto the trailer. Make sure that the safety chain is also attached from the Fly Wire™ trailer to the Decelinator's™ load hook.

Lower the Fly Wire™ trailer back to the full towing position.



Slightly raise the tower and lower the steel ram stop back onto the trailer. Lower the tower back onto the trailer.

Raise the platform and lower the steel ram stop to the side of the trailer.



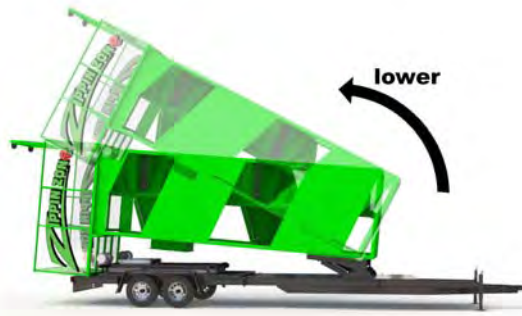

Lower the Fly Wire™ tower completely to the towing position. Remove the lift controller and store safely away.

Make sure the loading ramps are in place and secure.

Storing Ramps



Raise the ramps to the towing position.



Attach the safety chains to the brackets to hold the ramps in place. Bring in all of the chain slack to hold the ramps as far up as possible.



CAUTION: DO NOT tow the Fly Wire™ without the Decelinator's™ safety chain attached. Towing the Fly Wire™ without the Decelinator's™ safety chain attached can potentially cause a serious road hazard and severe damage to the Fly Wire™ and Decelinator™.



CAUTION: DO NOT tow the Fly Wire™ with the platform still partly raised. Ensure that the platform is down and in the full towing position, resting on the trailer.

Do a final inspection before towing away from event.

Inspect around the entire area where the Fly Wire™ was operating to ensure no equipment was left behind. Check for harnesses, zipline pulleys, carabiners and/or controllers.



Inspect the trailer, straps and connections to the towing vehicle. Test the indicator lights on the trailer to ensure they are all fully functioning. Abide by all towing safety rules when leaving the event.

10.0.Troubleshooting

If you have a problem with your mobile Fly Wire™, check the following table for solutions.

Problems and Solutions
<p>Jacks don't extend or retract</p> <ul style="list-style-type: none"> • Keeper pins may still be in place. Remove the keeper pins. (To this point they have been called drop leg pins.) • Inner ram tube of jack may be dirty. Remove obvious dirt, and then spray a little silicon lubricant to loosen the jack and extend it. When fully extended, clean the inner ram tube carefully and apply a light coating of silicon.
<p>Fly Wire™ or Decelinator™ won't raise or lower</p> <ul style="list-style-type: none"> • Controller may be malfunctioning. Make sure controller cable is not damaged. Wires may have been pulled loose in connector or receptacle. • Hydraulic pump may have a loose connector. Check and tighten connectors. • Battery may be low. Check the battery and recharge if necessary.
<p>Fly Wire™ seems unstable</p> <ul style="list-style-type: none"> • Surface may not be level. Make sure the setup surface is level. • Fly Wire™ location may be poor. Move the Fly Wire™ to a more solid, level location. • May be too windy. If wind conditions are 25 mph or above, lower the Fly Wire™ and don't use it until conditions improve. • Stabilizing jacks may not be properly or fully deployed. Deploy, secure, and level. • Fly Wire™ may not be vertical. Check by leveling and adjust jacks as needed
<p>Decelinator™ will not allow zipping properly</p> <ul style="list-style-type: none"> • Ensure that the Decelinator™ is at least 100 feet (30.80 meters) and no more than the 220 feet (67.07 meters) away from the Fly Wire™ platform. No more than 300 feet (91.44 meters) if your Fly Wire™ is equipped with this optional length. • Zip cords may be binding. Replace any worn parts causing binding on the Decelinator™. Zip cords may need to be replaced. • Decelinator™ may be located at an angle and not straight in front of the Fly Wire™ platform. • Inspect zipline pulleys and ensure they are Extreme Engineering zipline pulleys for proper function. • Check that the Decelinator™ is fully raised and in the upright position. • Make sure the battery to the Decelinator™ is fully charged.



Decelinator™ is moving while testing the zipline

- Make sure there is enough counterweight on the Decelinator™ to eliminate movement during the use of the zipline. It is recommended that you use 3,500 lbs or 70 Extreme Engineering sand bags (50 lbs each). Refer to the portion of the manual on proper counterweight and operational surfaces (page 63).
- Use stakes.

Decelinator™ will not move off the trailer

- Make sure the casters on the Decelinator™ are aligned with the trailer's track. If not, carefully align the wheels back on the track with a steel bar. NOTE: Rarely will this be an issue with your product. Refer to the portion of the manual on how to properly lower/raise the Decelinator™ from the trailer base.

Inflatable slide will not inflate

- Make sure that the inflatable blower is plugged into a working power outlet. Test that the blower power up by turning on the power switch.
- Make sure you are using the factory provided blower, a 1 HP inflatable blower for inflating the slide.
- Make sure the sock tube from the slide is securely fastened around the inflatable blower and not releasing air out of the sock tube.
- Make sure the zipper on the slide is zipped and not open, which would allow air out of the inflatable slide.

Brake lights/tail lights/turn signals don't work

- Connector may be loose or not connected. Make sure the trailer light/brake connector cable is firmly connected to the tow vehicle.
- Tow vehicle may have blown a fuse. Inspect the fuse and replace it if necessary.
- Wire may be broken. Make sure the connector cable is not damaged.
- Light bulbs may be broken or burned out. Replace the broken or dead bulbs.

Exit doors don't stay locked when Decelinator™ is in the up position

- Make sure the electrical cord is properly connected to the Decelinator™ and Fly Wire™ trailer to power the safety box.
- Tilt switch may need adjustment. The process is simple:
 1. Make sure the Decelinator™ is fully upright, with the tension set on the zip cords.
 2. Use 2 wrenches, loosen the bolts holding the gray tilt box.
 3. Tilt the mechanism back (toward the winches) until the doors are free to open, then continue another 5 degrees or so (approximately moving the top bolt an extra ¼ inch).
 4. Without allowing the tilt switch to move, tighten the bolts down such that the box cannot vibrate into another position. The main function of the tilt switch is to prevent the doors from opening with the Decelinator™ in the down position.
- Inspect connections on the cord and check that the cord has no kinks, cuts or signs of wear.
- Battery charge may be low. Refer to battery troubleshooting.



11.0. Frequently Asked Questions

What type of vehicle or additional equipment is needed to tow the portable Fly Wire™?

Extreme Engineering's Fly Wires™ weigh approximately 10,000 lbs (4,535.92 kilos). A class 5 tow hitch must be used. The ball size is 2 5/16" and the wire harness is a standard RV 7 way connector or a standard flat 4 way connector. The brake control (for the trailer brakes) and wire harness are standard installation for most RV centers and U-Haul facilities.

What type of insurance do I need, how much does it cost, where do I get it?

Most events require liability insurance. The cost can vary. We can furnish a list of insurance providers that are familiar with our equipment and requirements. Contact Extreme Engineering for information at 916-663-1560.

Is financing available?

Call Extreme Engineering at (916) 663-1560 for a list of recommended financial institutions, if available, to assist in your funding needs.

How much maintenance is required?

As with any equipment, general maintenance is required. However, maintenance tasks are simple and can be done yourself. A general log is recommended and the average maintenance for our customers depends on the amount of use of the product. We can proudly say that the Fly Wire™ was designed with cost of ownership in mind. Maintenance is minimal if you treat your product with care.

What type of harnesses and zipline pulleys can I use on the Fly Wire™?

For safe and proper operation, YOU MUST ONLY use Extreme Engineering OEM harnesses and zipline pulleys. Call our parts department for the correct Fly Wire™ equipment.



CAUTION: Failure to use Extreme Engineering zipline pulleys and harnesses can result in serious injury or death. You assume all risk and hold Extreme Engineering harmless by failing to abide by all safety rules in this manual and by not using OEM Extreme Engineering parts.

How long does it take to set up a mobile Fly Wire™?

The setup time is approximately 45 minutes – 1 hour. All mobile Fly Wires™ can be set up with two people. The push button hydraulic lift on Extreme Engineering mobile products make it safe, fast and easy to operate!

How many people can ride at the same time?

You can safely operate up to 2 people at the same time, one on each cable, at 250 lbs each.



How durable is the Fly Wire™?

The Fly Wire™ meets and exceeds ASTM, CE and other industry standards. All products come powder coated, zinc plated and galvanized. As long as you take care of your product, your Fly Wire™ is built to last with years of issue-free service.

How do I clean the Fly Wire™?

Most of our customers find it easy to go to a “coin-op” car wash. **DO NOT use high pressure wash nozzles directly on electrical components (battery cables, controller plugs, wiring harnesses, etc.).** High pressure can be used on everything else.

What types of events are most popular?

Fairs, festivals, school carnivals, graduation nights, zoos, college events, private parties, corporate team building, company picnics, radio promotions, store sales, parks and recreation events. The list is endless and is based on your creativity!

What is the typical gross earnings potential?

Contact our sales team for typical earnings at 916-663-1560. Potential earnings will vary on the type of events you operate, the demographics you cater to and the size of the venue.

My Decelinator™ will not lower.

Pull down on the Decelinator™ when holding the down button. Pressure from cable and no weight applied will not lower the Decelinator™. The pump is a single acting pump and when lowered releases pressure. With no weight applied the pump may lower slowly or not at all.

I cannot LOWER my Fly Wire™.

Check battery level by using jumpers to a running vehicle. Hook up the jumper cables the same as you would when attempting to jump start a vehicle. Check all battery cables for corrosion and tightness. Check all wires from plug on trailer-side to battery and pump motor looking for loose connections. Check controller-side plug for loose connections. Remove plug cover and inspect wires/connections.



CAUTION: DO NOT smoke or have an open flame near or around the battery. Smoking or having an open flame near or around the battery may result in serious injury.

I cannot RAISE my Fly Wire™.

Check battery level by using jumpers to a running vehicle. Hook up the jumper cables the same as you would when attempting to jump start a vehicle. Check all battery cables for corrosion and tightness. Check controller-side plug for loose connections. Remove plug cover and inspect wires/connections.



My pump on the Decelinator™ and/or Fly Wire™ makes sounds when I try to operate the controller but nothing happens.

Check battery level by using jumpers to a running vehicle. Hook up the jumper cables the same as you would when attempting to jump start a vehicle. Check all battery cables for corrosion and tightness. Check controller-side plug for loose connections. Remove plug cover and inspect wires/connections. Check the automatic transmission fluid level in tank.

12.0. Maintenance

Your mobile Fly Wire™ will give you years of trouble-free service if you take care of it. For safety, trouble-free operations and good appearance, follow the maintenance schedules provided here.

Log Book

A maintenance log book is essential for tracking the use of the Fly Wire™. If you record the date, number of daily cycles, and number of cumulative cycles, this record will allow you to anticipate when some maintenance tasks (such as replacing zip cords, harnesses and zipline pulleys should occur. We have a maintenance log sheet included toward the end of this manual. Please make copies of the maintenance log sheets to create a log book for you and your staff.

Maintenance procedures and inspection logs

Read the inspection procedures on the following pages. Be sure to use copies of the inspection checklists provided in this manual to keep a record of your inspections.

Detailed description of inspection items

Inspect the mobile Fly Wire™ thoroughly before you take it out to use it. Your safety on the road, during setup and your participants' safety depend on it!

Zip cords

Check the zip cords for fraying, broken strands, kinks, wear, smoothing, reduced diameter, or damage. Run your hands along the entire length of the cords, checking for a wavy or uneven feel to the cord. Wear gloves when using your hands to prevent getting cut by a broken strand. Also check that the spring packs and sleeves show no signs of wear or visible damage.





CAUTION: ALWAYS REPLACE YOUR ZIP CORDS EVERY YEAR OR 10,000 ZIP CYCLES PER PAIR (5,000 PER CORD), WHICHEVER COMES FIRST, OR IF THE CABLE ASSEMBLY IS NO LONGER SAFE TO USE. YOU, YOUR STAFF, AND YOUR CLIENTS DEPEND ON IT. FAILURE TO DO SO MAY RESULT IN SERIOUS INJURY AND/OR DEATH. FAILURE TO DO SO WILL VOID THE FLY WIRE™ WARRANTY. YOU ASSUME ALL RISK AND HOLD EXTREME ENGINEERING HARMLESS IF YOU FAIL TO ABIDE BY THE SAFETY RULES IN THIS MANUAL AND/OR FAIL TO REPLACE COMPONENTS WITH OEM EXTREME ENGINEERING PARTS. “IF IN DOUBT, SWAP IT OUT.”



CAUTION: Always replace any suspect cable. This is absolutely critical for safe operation! If you suspect a cable is damaged, or are not sure, visit our tech page at www.extremeengineering.com or call customer service for assistance before operating the system!



CAUTION: YOU MUST ONLY USE Extreme Engineering’s zip cord assembly replacing your zipline cords. Aftermarket rope, cords, springs and/or cable will not function properly, will cause severe damage to your Fly Wire™ and serious injuries or death. Extreme Engineering uses an exclusively designed steel cord specifically designed for the Fly Wire™. DO NOT USE ANYTHING ELSE BUT Extreme Engineering zip cords. You assume all risk and hold Extreme Engineering harmless by failing to follow the safety procedures in this manual.

Cords should be replaced every 12 calendar months from date of manufacture or 10,000 zip cycles (a zip cycle is once down the Fly Wire™ zipline and off the Decelinator™) per pair (or 5,000 per cord), whichever comes first, even if there are no visual signs of wear. “If in doubt, swap it out.”

Extreme Engineering Zipline Pulleys

Make sure the zip cords are traveling through the zipline pulleys without binding. Make sure all the pulleys are turning smoothly and are not worn.

Decelinator™

Inspect the Decelinator™ system thoroughly for wear in and around the winches. Also inspect the zip cords wrapped around the winches for wear. Check that the pulley guides are fully functional and the pulleys are not worn. Make sure the cable clamps and tension gauges are operational with no signs of wear or damage. Make sure the zip cord covers have no tears. If the cable clamps, zip cord covers and/or pulley guides need replacement call customer service to replace your Decelinator™ parts.

Check the hydraulic pump for any leaks, kinks in the hose, rust around the solenoids and battery terminals for corrosion. Carefully look over the Decelinator’s™ coil springs for



fractures, wear and/or cracks. Look over the complete base of the Decelinator™, including casters, checking for cracks in the welds and rust. Also inspect the friction plates on the bottom of the Decelinator™ for sufficient tread. Call customer service for assistance in ordering and replacing Decelinator™ parts. Touch up any rust with high-quality, black spray paint.

Hydraulic Hose

Make sure the hoses on both the hydraulic pumps (Fly Wire™ and Decelinator™) are not leaking. If you find a leak, call customer service for assistance.

Fly Wire™ Platform

Inspect the entire zipline platform for cracks in the welds, rust in the steel or obvious signs of wear in the stairwells. Ensure that the exit gate at the top of the platform is fully functional and the locking mechanism is in safe, working order. Test the exit gate and locking mechanism several times to ensure functional operation. Inspect the zipline cord attachment points at the top of the platform for signs of wear and/or rust. Also inspect that the bimini attachments are not worn or damaged. Touch up any rust with high-quality, black spray paint.



CAUTION: DO NOT weld on the steel substructure or modify the platform. Welding on the steel substructure or modifying the platform will void your warranty and cause severe issues with your Fly Wire™.

Fly Wire™ Lift System

Raise and lower the Fly Wire™. Make sure the Fly Wire™ lifts smoothly and completely. If the Fly Wire™ does not raise or lower completely, or if there is any hesitation in its motion, contact customer service.

Check that all connectors on the hydraulic lift pump are properly tightened (control cable, power, and ground). Tighten if necessary.

Jacks/Outriggers

Let out each extending jack as far as possible and clean the inner ram tube. Coat the tube with a light coat of silicon spray lubricant. Make sure there are no missing drop legs and/or drop leg pins.

Trailer Hitch

Make sure the trailer hitch is of the proper weight capacity and the towing ball is a 2 5/16 diameter. Inspect the safety cable and its mounting hardware for wear. If at all questionable, replace it.





CAUTION: If you are in any doubt about the hitch or the safety cable, consult Extreme Engineering or an automotive or RV service center. This is critical for safe transport. A trailer becoming unhitched during transport can be a catastrophic.

Trailer Tongue

Make sure the bolts holding the trailer tongue to the trailer are tight. If the tongue is welded, check that there are no cracks and/or fractures in the welds. Also, ensure that the trailer tongue is not warped, bent or contain broken welds or cracks in the steel. If there is rust on the trailer tongue please touch it up with high-quality, black spray paint. **DO NOT** weld or modify the tongue. Welding or modifying the tongue will void your warranty and cause severe issues with the Fly Wire™.

Trailer Wheels

Make sure the lug nuts are tight. Lug nuts should be checked every 500 miles. **DO NOT** tow the Fly Wire™ if lug nuts are missing from the wheels. Replace lug nuts if they are missing.

Trailer Lights

Connect the trailer light and brake connector to a towing vehicle. Be sure the tail lights, brake lights, running lights and turn signals are performing correctly. **DO NOT** tow the Fly Wire™ if the trailer lights are malfunctioning. Fix the trailer lights before towing.

Replace any broken or burned out bulbs. Keep spare bulbs on hand. When troubleshooting lights, remember to check the tow vehicle's fuses and replace as necessary. Check for broken light lenses and replace if necessary.

Failure to keep your lights in good condition can result in serious road hazards when towing.

Electrical Cord for Auto-locking Doors.

Make sure that the electrical cord which connects to the Decelinator™ and Fly Wire™ platform to activate the auto-locking doors has no signs of wear. Inspect the entire length of the electrical cord for kinks, cuts or other signs of wear. Replace if necessary.

Inflatable Slide (if applicable)

Inspect the vinyl on the inflatable slide for any tears or cuts. Ensure that the inflatable slide's tie-down straps for the tent stakes and/or sand bags are not torn and are in good working condition. Feel up and down the vinyl for any abrasions or severe scuff marks. Check around the connection tube for the inflatable slide located on the Fly Wire™



platform. Also inspect that the connection tube doesn't have any cracks and is tightened to the substructure. Look for any potential loose or missing hardware. Replace and tighten any loose or missing hardware. Do a final inspection on the inflatable slide by testing out the blower and inflating the slide. Repair any holes in the slide. If the inflatable blower is not working correctly, replace the inflatable blower. Ensure that the proper tent stakes and/or sand bags are with the slide. Call customer service to order your replacement blower and/or slide components.

Loose or Broken Parts

Inspect the entire mobile Fly Wire™ for loose or broken parts. Replace broken parts (call customer service to order) and tighten loose parts.

Hitch Pins

Hitch pins are an additional safety measure. Keep spares on hand. Only replace with pins of equal quality.



CAUTION: For both use and transport, never modify, alter, or adapt your equipment with anything other than the correct keeper pins or safety snap pins! Doing so could create a serious hazard! **Use only OEM Extreme Engineering parts.**

Harness

Protect your harnesses from constant direct sunlight and heat and from nylon-damaging substances such as acids, alkalis, oxidizing agents and bleach. Four of the most common signs of damage and/or wear are from the following:

1. UV Damage

Ultraviolet light can be one of the worst kinds of damage on a harness. The good news is that it is easy to spot. Discoloration and general fading indicates prolonged exposure to the sun. Virtually every modern harness is made up of UV-sensitive polymers. These polymers and threads lose much of their strength with prolonged exposure to sunlight.

2. Webbing Condition

It applies as in point 1., but in addition to UV damage wear is a huge factor. Most webbing exhibits “fuzz” near the buckle areas making it extremely difficult to adjust properly, see Fig. 1e. Any rips or cuts cannot be tolerated. To properly retire a climbing harness the harness should be cut into small pieces then disposed.



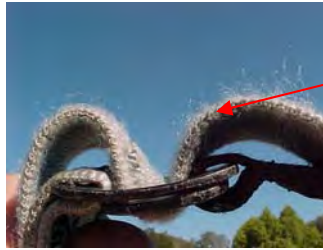

Fuzzy webbing

Fig 1e.

3. Tread Conditions

Key stitching around the tie in point and leg loops must be in excellent condition. NO LOOSE THREADS!

3. Buckle Conditions

If the buckles and/or latch condition show signs of severe wear, notches in the buckles or malfunction in the locking mechanism please no longer use the harness. Properly dispose of the harness and replace with an OEM harness.

Carabiner

Make sure the carabiners lock properly. All surfaces of the carabiners should be free of cracks, sharp edges, corrosion, burrs or excessive wear. Be sure the gate and any locking mechanism closes freely and completely. Gate opening and closing should be quick and easy. If washing and drying does not remedy a gummed-up carabiner, replace it. Replace carabiners if they are worn or damaged.



Failure to replace worn carabiners can result in severe fractures or breakage.



CAUTION: If a carabiner does not pass inspection (even after cleaning), destroy and replace it with a new one. This is absolutely critical for safe operation. Always keep a spare carabiner on hand.



13.0. Replacing Zip Cord assembly



NOTE: Have the Decelinator™ removed from the Fly Wire™ for easy access to the winches to exchange the zip cords. New zip cords include the spring packs as part of the assembly.

13.1. Remove the old zip cord assembly



NOTE: You will need the winch controllers plugged into the Decelinator™ to release and bring in cable when replacing zip cords. You can refer to the Decelinator™ operational section found in this manual for instructions on using the winch controllers.

Engage the release switch on the Decelinator's™ winch to “free spool” and pull out all of the zip cords from the system. To prevent causing a mess of tangled cords, tightly wind the used zip cords. Once you removed most of the zip cords from the winch, remove the termination point of the cord that is attached to the winch. After the used zip cords are completely removed from the winch **DO NOT** store them with the unit. Recycle them, or have the old cords destroyed so that they do not mistakenly get reused on the Decelinator™. **DO NOT** try to reuse the spring pack assembly. The new zip cords already come equipped with the new spring packs.



CAUTION: DO NOT put worn compression springs back onto new zip cords! Failure to use a new, complete assembly of Extreme Engineering zip cords can result in serious injury and/or death. Failure to use a complete assembly will also void the product warranty. You assume all risk and hold Extreme Engineering harmless by not following the safety procedures in this manual or not using OEM Extreme Engineering parts.

13.2. Replace the new zip cords



CAUTION: DO NOT use aftermarket cords, rope and/or cable. **ONLY** use Extreme Engineering's zip cords specifically engineered and designed for the Decelinator™ and Fly Wire™ system. Failure to use Extreme Engineering's zip cords will result in serious injury and/or death. Failure to use Extreme Engineering's zip cords will also void the product warranty. You assume all risk and hold Extreme Engineering harmless by not following the safety procedures in this manual or not using OEM Extreme Engineering parts.

Unwrap the new Extreme Engineering zip cords and carefully fasten the termination end of the cords back into the winch. Turn the switch on the Decelinator's™ winch to “engaged” so you can wind in the new zip cords. When winding the new zip cords onto the winch, make sure that the cords do not bundle or get tangled. The cords should easily wind back and forth along the winch's roller.





CAUTION: DO NOT operate the Decelinator™ without the cords being securely fastened to the winch. Operating the Decelinator™ without the cords being securely fastened to the winch can result in serious injuries and/or death. Cords **MUST** be fastened to the winch before operation and during the replacement procedure.

13.3. Test the new zip cords on the Fly Wire™

Always test the new cords on the Fly Wire™ with sand bags first. NEVER human test the Fly Wire™ without testing with sand bags first. Ensure that testing proves both the Decelinator™ and Fly Wire™ are operating correctly and safely. There should be no tangling in the winch, jerking motion with the cords engaging/disengaging from the Decelinator™ and/or awkward movement on the Fly Wire™ during use.

Refer to the test Fly Wire™ portion found in this manual for further details on testing your Fly Wire™ product.

Inspect all components inside the Decelinator™ for proper operation, damage or oil leakage.

If at any time you are unsure whether the Decelinator™ is malfunctioning, contact Extreme Engineering's technical support for further troubleshooting assistance at 916-663-1560.

14.0. Replacing Cable on Loading/Offloading Fly Wire™ Winch

14.1. Remove the Old Cable From the Fly Wire™ Winch

The winch located on the trailer base of the Fly Wire™, located toward the tongue of the trailer, is used to load/offload the Decelinator™ from the Fly Wire™ trailer. This winch will rarely need replacement cable and if properly maintained will provide you years of trouble-free service. In the event that the cable winch is worn and in need of replacement, follow the similar steps above when replacing the Decelinator™ cords.

This winch, unlike the Decelinator™, doesn't use zip cords and uses a standard steel cable. This cable is not an Extreme Engineering cable. As long as you abide by the winch's cable specifications when replacing, operations of the winch will be safe. The use of this winch is very different from the Decelinator™ and is not designed for human lift. **DO NOT** use non-compatible cable or different cable size on the winch. **DO NOT** use the winch for any other purpose but offloading/loading the Decelinator™ from the Fly Wire™.

If you have any concerns and/or questions on winch cable replacement please feel free to call technical support for assistance at 916-663-1560.



15.0. Cleaning and Other Special Care

Fly Wire™ Trailer, Platform and Decelinator™

Clean the mobile Fly Wire™ as you would a boat, camper or recreational vehicle. Hose it off. Use a solution of warm water and dish soap to remove dirt from the Fly Wire™ and trailer. You may use a degreaser as long as you don't degrease around any lubricated parts, such as the lift rams, winches, lift pumps, hitch, etc.

Carabiners

Keep carabiners dry and clean. Protect them from corrosion. **DO NOT** store them in very humid or salty air, with damp equipment or clothing, or near corrosive chemicals. **DO NOT** file carabiners for any reason. If notches or fractures appear, replace the carabiner. If a carabiner gate sticks, wash it in warm soapy water, rinse thoroughly and lubricate with either dry graphite or Teflon lubricant around the hinge area, inside the spring hole and locking mechanism.



CAUTION: DO NOT use non-locking carabiners, aluminum carabiners or any other type of carabiner that is not greater than or equal to the specifications on the original carabiners provided. To ensure the correct carabiners are used on the Fly Wire™ purchase your carabiners from Extreme Engineering.

Extreme Engineering Zipline Pulleys

Keep the zipline pulleys dry and clean. Protect them from corrosion. **DO NOT** store them in very humid or salty air, with damp equipment or clothing, or near corrosive chemicals. **DO NOT** file or bend the zipline pulleys for any reason. If notches or fractures appear, replace the zipline pulleys with Extreme Engineering zipline pulleys only. If a zipline pulley's bushing sticks, wash it in warm soapy water, rinse thoroughly and lubricate with either dry graphite or Teflon lubricant around the bushing area. If this doesn't resolve the issue, replace the zipline pulley with Extreme Engineering zipline pulleys only. **ONLY USE OEM ZIPLINE PULLEYS BY EXTREME ENGINEERING.**



CAUTION: DO NOT use aftermarket zipline pulleys on the Fly Wire™. Using aftermarket zipline pulleys can result in severe malfunctions with the Fly Wire™, injury and/or death. Only replace your zipline pulleys with Extreme Engineering zipline pulleys, specifically designed for the Decelinator™ and zip cord components. Failure to do so will void your product warranty.



Zipline Harnesses

Hand-wash a dirty harness in cool water with a mild soap. Allow it to dry in a shaded area. Always store your zipline harnesses indoors, away from a humid or salty air environment. **DO NOT** store harnesses for extended periods in direct sunlight



CAUTION: DO NOT use aftermarket harnesses or non-Extreme Engineering zipline harnesses. Using aftermarket or non-Extreme Engineering zipline harnesses can result in serious injuries and/or death. Using aftermarket or non-Extreme Engineering zipline harnesses will void the product warranty.

15.1. Protection From the Elements

Store the mobile Fly Wire™ as you would a boat, camper or recreational vehicle.

Storing the mobile Fly Wire™ in a covered shelter or garage will keep it cleaner and preserve its appearance longer.

Storing the mobile Fly Wire™ outdoors is not a problem; however, you may want to place a tarp over the Fly Wire™ to preserve the finish from excessive exposure to the sun. To prevent damage, the tarp needs to allow air circulation. Trapping moisture under a polypropylene tarp can lead to rust or corrosion damage on the components.

15.2. Quick Checklists and Log

On the next four pages you will find condensed maintenance checklists, plus a maintenance log sheet, which you can photocopy and use.

15.3. Per-Use Maintenance Checklist

Zip Cords

Check for kinks, wear or damage to the zip cords. Never repair or mend, always replace suspect zip cords with Extreme Engineering zip cords only.

Check for Fraying or Broken Strands

Check for kinks, wear or damage to the zip cords. Never repair or mend, always replace suspect zip cords with Extreme Engineering zip cords only.

Decelinator™

Must not be worn, damaged or contain rust. Check the winch for proper and safe operation. Inspect that the casters can move freely and be used during operation. Check that both the cable clamps and pulley guides are properly functioning.



Fly Wire™ Offload/Loading Winch

Check that the offload/loading winch on the Fly Wire™ (used for the Decelinator™) is in safe and proper operation. Make sure the cable doesn't have any kinks, frays or signs of severe wear.

Hydraulic Hose

Check for leaks at ram or pump ends. This also should be checked on the Decelinator™.

Fly Wire™ Platform

Check for any cracks or fractures on the steel substructure. Inspect that the exit gate can properly lock and unlock.

Bimini (optional)

Ensure that the bimini assembly is complete and in working order. Examine the flex rods for any fractures and/or cracks. Check that the lock-down pins are complete and fully functioning. Also inspect the vinyl cover for any tears and/or cuts. Always store your bimini assembly indoors and not in a humid and/or salty air environment.

Inflatable Slide (optional)

Check the inflatable slide for any holes and/or cuts. Make sure the PVC cover that is applied to the inside of the slide has no tears and that the velcro still attaches. Inspect the sock tube for any holes and/or cuts. Make sure the zipper on the inflatable slide is fully functional. Ensure that the connection tube on the Fly Wire™ contains no missing hardware and is fully fastened to the steel substructure. Make sure that the connection chains and straps are included with the slide and are in working order.

Electrical Cord for Auto-locking Doors

Check that the electrical cord contains no cuts, kinks or signs of wear. Check that the connections are not broken and are in good working order. Replace if broken or damaged.

Trailer Lights

All tail, brake, running and turn signal lights should be working.

Trailer Tires

Keep pressure at 80 psi (factory original or duplicate replacement) or to manufacturer's specifications. Tread must be adequate, with no objects in treads. Also check the spare tire (if applicable).

Keeper Pins

Be sure spares are on hand.

Harnesses

Must be in good condition, not worn. When dirty, hand wash in cool water and dry in a shaded area (not in direct sunlight). Inspect that the zipline lanyards are in good working condition.



Zipline Pulleys

Ensure that the zipline pulleys are in working order and that the pulleys spin freely. Inspect the body of the zipline pulley for any fractures, rust or missing parts.

Carabiners

Check for bent, loose, or missing rivets. The gate/lock must close freely. If gummed up, clean with soapy water and dry.

15.4. Periodic Maintenance Checklist

Thoroughly inspect the mobile Fly Wire™ before every use.

- **Do the per-use and maintenance checklist first.**
- **Loose or broken parts.** Replace broken parts; tighten loose parts.
- **Trailer hitch.** Be sure the hitch, hitch lock, and light/brake cable all are operating correctly. Be sure the safety cable is OK.
- **Trailer tongue.** Make sure the bolts are tight.
- **Trailer wheels.** Make sure lug nuts are tight.
- **Trailer electric brakes.** Check for correct operation of the brakes and breakaway switch.
- **Jacks.** Extend all jacks and clean inner ram tubes. Coat with silicon spray lubricant.
- **Fly Wire™ and Decelinator™ lift system.** Be sure that both the Fly Wire™ and Decelinator™ lift smoothly. Check that connectors on the hydraulic lift pump are tight (control cable, power, and ground). Tighten if needed.
- **Battery.** Check terminals for corrosion; clean if needed.
- **Decelinator™ winch.** Check that cord slack is taken up and paid out correctly. Also make sure that the cords are free of broken strands, corrosion, rust, frays, or any other defects. Test the winch by releasing and taking in slack.
- **Pulleys.** Check the pulleys on the tension plates of the Decelinator™ for signs of wear. Visually inspect that no grooves appear in the pulleys.



- **Fly Wire™ winch.** Check that cable slack is taken up and paid out correctly. Also make sure that the cable is free of broken strands, corrosion, rust, frays, or any other defects. Test the winch by releasing and taking in slack.
- **Clean Fly Wire™ and trailer.** Wash with soap and water.

© Extreme Engineering



16.0.Safe Towing Tips

We encourage you to be a safe, courteous driver when towing your mobile Fly Wire™. Keep the following in mind when towing your Fly Wire™.

- ✓ Be sure that the lug nuts are tightened.
- ✓ Be sure to use the safety cable or chains at all times.
- ✓ Be sure the tail lights, brake lights and turn signals are functioning correctly.
- ✓ Be sure the trailer's brakes are working correctly.
- ✓ Be sure your trailer is properly registered with your state's department of motor vehicles (DMV).
- ✓ Always observe the posted speed limits for trailers when towing your mobile Fly Wire™, and be especially cautious (and reduce your speed) when encountering windy, snowy or rainy conditions.
- ✓ Install extended side rearview mirrors on your towing vehicle. Your mobile Fly Wire™ is more than 24 feet in length and you'll need the extended mirrors to see traffic directly behind you.
- ✓ Signal before changing lanes. When you change lanes, be aware of traffic behind you and at your sides. Allow plenty of clearance before changing lanes.
- ✓ **DO NOT** attempt to make tight left or right turns.
- ✓ Practice backing up where there is plenty of room before you try it in a real-life situation. To back up a trailer, turn the steering wheel the opposite direction from the direction you want the trailer to move.



17.0. Specifications

17.1. Fly Wire™ Trailer Specifications

Overall Length	33' (10.1 M) Tow tongue to bottom of trailer frame 41' (12.5M) Tow tongue to tip of Fly Wire™ platform with bimini
Height Raised	34' (10.36 M) Tow tongue to top of Fly Wire™ platform with bimini
Height Lowered	12' (3.66 M) Fly Wire™ horizontal, highest point
Overall Width	8' (2.43 M) Outside tower frame
Trailer Base Width	8' (2.43 M) with jacks in towing position
Fly Wire™ Platform Height	34' (10.36 M) with bimini attached, without is under 30' 6" (9.14 M)
Maximum Gross Vehicle Weight	10,000 Lbs (4,545.45 Kgs)
Tongue Weight	Approximately 1000 Lbs (454.54 Kgs)
Inflatable Slide Weight	450 Lbs (204.55 Kgs)
Trailer Type	Tandem axle with fenders
Axles	7,000 Lbs (3181.18 Kgs) maximum load PER axle 4" drop Heavy duty tapered roller bearings 4 leaf springs One rear brake axle One front idler axle
Brakes	Dual electric brakes on rear axle
Hitch Requirements	Class 3 – 5000 Lbs (2272.72 Kgs) Class 4 – 7000 Lbs (3181.81 Kgs) Maximum Gross Vehicle Weights
Coupler Specifications	12,000 Lbs (5443.1 Kgs) rated Type – Formed bolt-on Ball diameter – 2 5/16" (58.75 Mm) Grade 8 Bolt Torque – 150 Ft-lbs (20.74 Kg-m)
Tire pressure	80 psi cold or specified on trailer tires
Wiring	Standard RV 7-way towing plug 12 olt DC



17.2. Mobile Fly Wire™ Lift Pump Specifications

Lift Pump	12 volt hydraulic Dextron III/Mercon Automatic Transmission Fluid Filled capacity 10 quarts Powered up and powered down
------------------	--------------------------------------------------------------------------------------------------------------------------------------------------------------

17.3. Decelinator™ Specifications

Lift Pump	12 volt hydraulic Dextron III/Mercon Automatic Transmission Fluid Filled capacity 10 quarts Powered up and powered down
Winch	12 volt 8,000 Lbs (3628.74 Kgs) rated winch or specified on trailer
Zipline Cords	Extreme Engineering zip cords with dynamic compression springs, patent pending and TM pending
Zipline Pulleys	Extreme Engineering zipline pulley, polycarbonate zip line wheel with sealed bushing. Steel safety plates. Load tested at 2,000 Lbs (909.09 Kgs) or as specified on the zipline pulley.
Zipline Capacity	Two per each Decelinator™, one per zipline cord. You can have up to two people zipline, up to 250 lbs each, at the same time.
Weight Limits	45 – 250 lbs (harness capacity)

17.4. Trailer Winch

Winch	12 volt 4,000 Lbs (1814.37 Kgs) rated winch or as specified on trailer
--------------	-------------------------------------------------------------------------------



18.0. Wiring Diagrams

LIFT CONTROLLERS WIRING DIAGRAM (Black controllers)

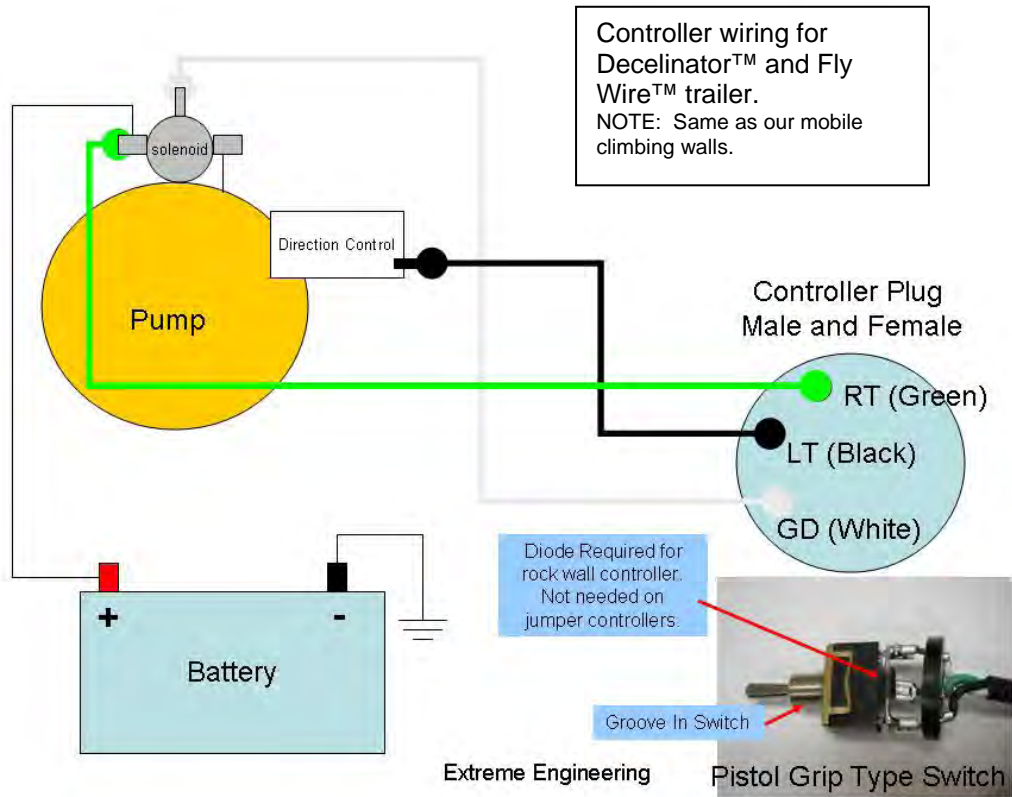

Trailer side Connector

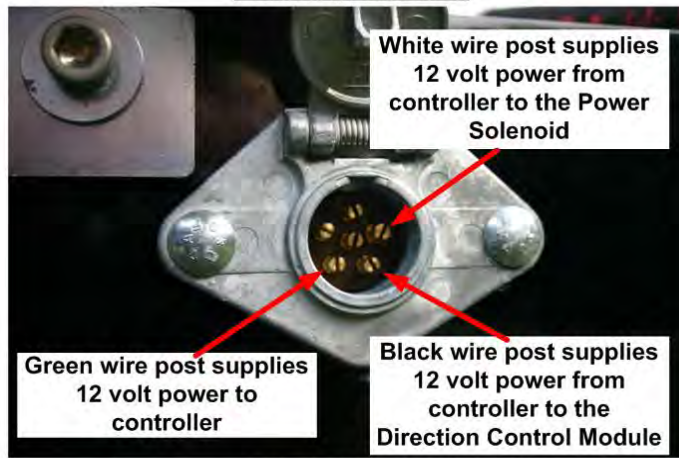

Controller Side Connector

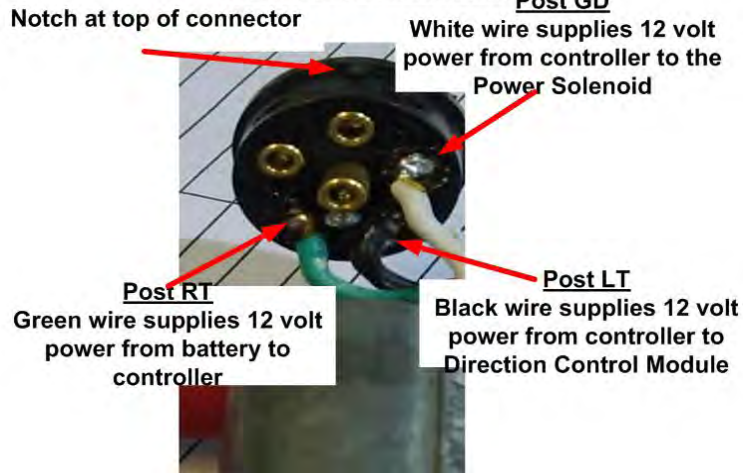

Trailer Wiring Diagram

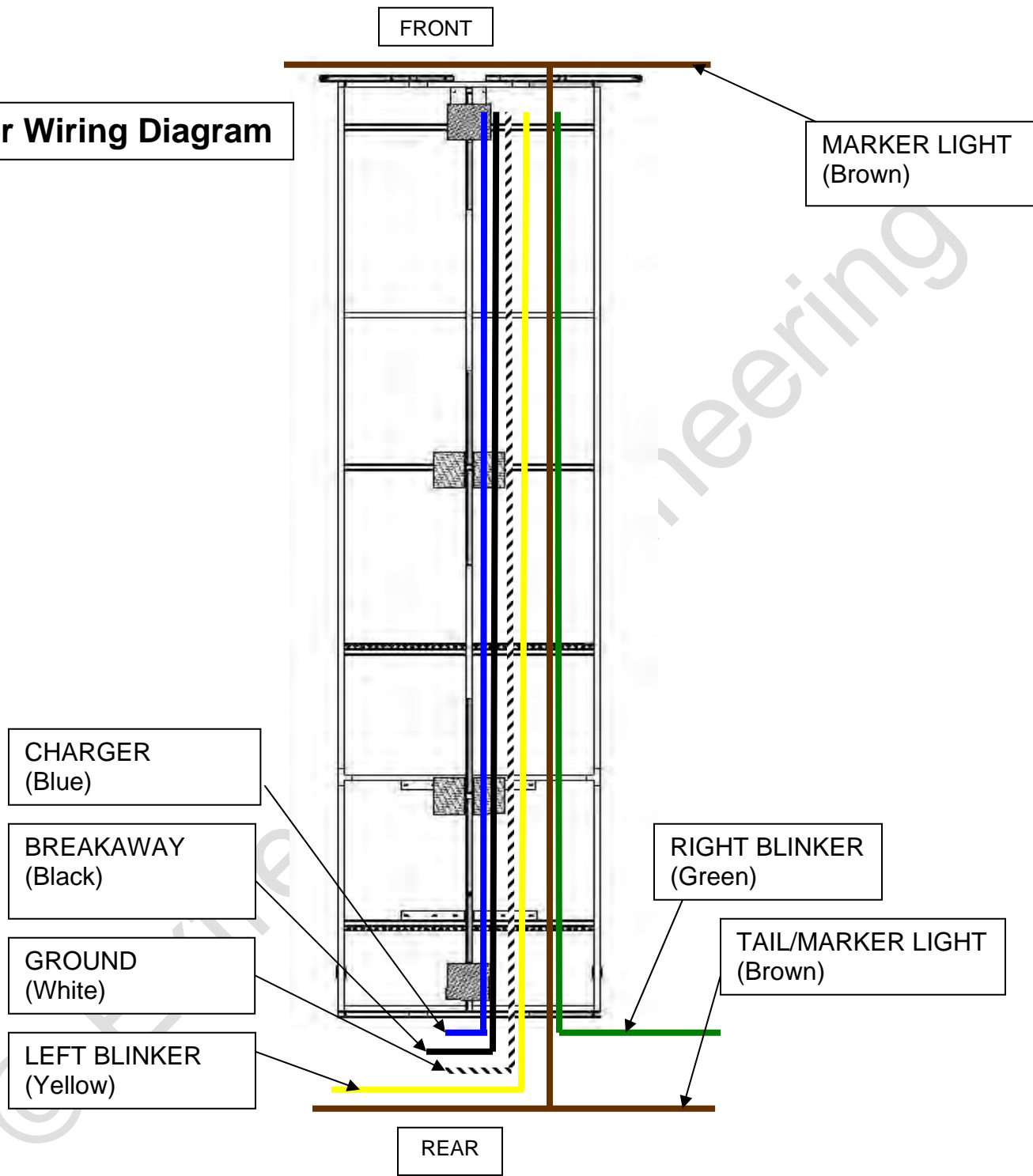

Battery Maintenance



WARNING: Testing electrical components can cause them to fail or burn out if the testing is not performed carefully and properly. Extreme Engineering is not responsible for any damages to electronic devices as a result of improper handling and/or testing of components.



CAUTION: Performing battery maintenance requires extreme care. Always wear protective equipment (e.g. safety glasses/goggles) and clothing (e.g. gloves) when working around lead acid batteries. The battery acid is highly caustic and can cause severe injury as well as damage to clothing, paint and other materials if not properly handled. If you are unsure of proper handling and maintenance techniques for these types of batteries, have a trained professional perform the required actions.



CAUTION: DO NOT smoke or have an open flame when working near the batteries.



CAUTION: When replacing, repairing, or performing maintenance on batteries or electrical systems operated by the battery, always disconnect the negative (-) battery cable prior to performing any other actions. This will prevent possible damage to electrical parts or self-injury due to the potential for sparks that can be generated by the electrical power. Always re-attach the negative battery cable as the final action.



CAUTION: Always perform maintenance on batteries in a well-ventilated area and well away from all flammable liquids and vapors (e.g. paint, gasoline, aerosol spray cans, etc). Unexpected sparks from the battery or electrical components can cause flammable liquids and/or vapors to ignite causing fire hazards.



CAUTION: Pressure buildup during charging can cause the battery to explode if the battery cell caps are not removed while charging.

Battery maintenance consists of the following actions and should be done every time the batteries are charged:

Check the liquid level in the battery for proper fill. If water must be added, **DO NOT use tap water**. Instead, use distilled water. The water level must cover the lead plates inside each compartment of the battery completely. These plates may be visible when the fill caps are removed. Most batteries provide a full level indicator inside at the bottom of the fill hole. DO NOT overfill the battery cells. Each cell is a separate compartment inside the battery. Therefore, each cell must have its cap removed for checking and filling.

Check all the battery cables and wires where they attach to the posts on the battery for corrosion and/or acid buildup. The cables, wires and posts should be kept free from this



buildup. A solution of water and baking soda can be sprayed onto acid buildup to neutralize the acid. It may take several passes of spraying the solution before the acid is completely neutralized. Once the acid is fully neutralized, the cables can be removed from their attaching posts and any remaining acid can be removed by brushing it away with a wire brush. Automotive stores sell sets of small green and red disks coated with an acid preventative solution which helps to control acid buildup.

Check for damage to the outside of the battery casing. If damaged, replace the battery.

Check for fluid leakage other than around the fill caps. If leakage is found, replace the battery.

Periodic charging must be performed. It is recommended to charge the battery frequently, preferably after each day's use, with a smart charger (available at any hardware store or Wal-Mart.) Extreme Engineering recommends the "Black and Decker" smart charger models.

18.1. Marine Deep Cycle Battery Required

Extreme Engineering utilizes a deep cycle, Group 27, 12 volt DC, marine battery rated for use with boat trolling motors on all mobile Fly Wire™ products.

The purpose of this type of battery is to supply electricity for a given period of time before it needs to be recharged. This is different than one designed for automotive engine starting which requires high current demands for a short period of time. The deep cycle battery cannot supply high current demands but can supply lesser current for a longer period of time without damage.

Operating for extended lengths of time at less than full charge with deeper discharges causes increased buildup on the plates inside the battery. This buildup prevents electricity from flowing and therefore provides less and less power over time.

Because of this, deep cycle batteries require maintenance.

Recharge as soon as possible after each use and maintain the state of charge at 100% to prevent permanent buildup on the internal battery lead plates.

When in storage, continuous float charging (charging at low current, about 1 amp) is the best way to prevent buildup. Or recharge before the state of charge drops to 80%. Buildup kills more than 80% of deep cycle batteries.

Reducing the average depth of discharge (DoD) will significantly increase a deep cycle battery's life. For example, a battery with an average of 50% DoD will last twice as long (or more) as an 80% DoD; a 20% DoD will last five times longer than a 50% DoD. Try to avoid DoDs that are greater than 80%. Industrial, traction, and stationary deep cycle batteries



with solid lead plates are designed for average of 80% DoD and most Marine/RVs designed for average 50% DoD.

Never discharge to less than 10.5 volts.

18.2. Battery Operation

A fully charged, new battery of the proper type can provide from five and to eight lift/lower cycles between charges on the Fly Wire™ trailer. The Decelinator™ will provide more cycles since the battery is under less usage. Typically the Decelinator's™ battery will provide enough cycles on a full charge during a single-day event. Under normal usage, even with periodic maintenance and charging, the number of lift/lower cycles will reduce over time. Eventually, the battery will not be able to operate the Fly Wire™ and Decelinator™ at all and must be replaced. This is a normal condition.

The default mode of the pumps is to raise the Fly Wire™ and Decelinator™. The Direction Control Module reverses the flow direction of the automatic transmission oil and this causes the Fly Wire™ and Decelinator™ to lower when the controller's down mode is initiated by the Fly Wire™ operator. As the voltage supplied from the battery drops, the Fly Wire™ and Decelinator™ will begin to raise slower than normal. With continued use without charging, as the battery supplies less and less voltage, the Fly Wire™ and Decelinator™ may raise successfully but the Fly Wire™ may not lower completely or may not lower at all. This is because there may be enough power from the battery to operate the pump motor but not enough power to operate both the Direction Control Module and the pump motor at the same time.



NOTE: The Decelinator™ doesn't use the battery when lowering and requires a fraction of combined power and hydraulic pressure, providing a much longer life for the operations of the battery.

When the voltage supplied from the battery begins to decrease below a specific level, this will result in less efficient operation of the pump. This also causes excessive heat generation throughout the whole electrical system during operation. This excessive heat can cause the electrical components, including the pump motor, to fail and require replacement. The reduced efficiency, excessive heat generation and possible component failure is not isolated to just Extreme Engineering mobile Fly Wire's™. This condition is the same for any product which utilizes this style of battery.

To ensure the mobile Fly Wire™ operates properly, Extreme Engineering recommends the batteries be replaced at the start of the customer's operating season annually.

A weak battery can cause problems with raising and lowering the Fly Wire™™, as well as with the Decelinator™, demonstrating symptoms similar to possible controller issues, pump issues or hydraulic issues. Before troubleshooting any of these other areas, have the



battery tested to ensure all cells are good, the electrolyte level is appropriate for the battery, and the battery can take and maintain a full charge for the proper period of time.

18.3. Battery Charging

The battery should be charged on a regular basis. Ideally, the battery should be fully charged after every use. The negative (-) battery cable should be disconnected from the battery while charging. Remove the battery cell caps to prevent pressure buildup inside the battery during charging. This pressure buildup can be significant enough to cause the battery to explode during charging.

For factory supplied batteries, if the battery charger has a setting for battery types, set it to the wet cell position.

Extreme Engineering adds the capability to maintain the battery charge from the tow vehicle. This is accomplished through the electrical connection between the mobile Fly Wire™ and the tow vehicle using the standard Recreational Vehicle 7-wire configuration via the black 12 volt (black/red) as seen in the below diagram.



RV 7-Wire Wiring Diagram



NOTE: Even though the battery receives a charge voltage from the tow vehicle during towing, a battery may not be properly recharged to a sufficient level while the mobile Fly Wire™ is being towed. To achieve a proper charge for the battery, the towing vehicle would potentially need to tow the Fly Wire™ for several hundred miles. Even then, the battery may not have a sufficient charge for raising and lowering the Fly Wire™.

18.4. What is and Why Use a “Smart Charger”

Extreme Engineering recommends using a battery charger that contains Smart Charger technology.



Why use a Smart Charger?

Smart Chargers DO NOT have any timers. All decisions are based on the battery's voltage and current. The charger may stay in either of the below first two states as long as necessary to achieve a proper battery charge.

Smart Chargers provide pure DC output which provides a faster, more complete and stable charge. Many conventional chargers output pulsating DC current which is significantly below rated amperage specifications.

A Smart Charger has three distinct operating stages.

At stage one (Bulk/Rapid mode), the charger limits the maximum charging current to a preset value while monitoring the battery voltage. Faster than conventional type chargers, even in freezing or high temperatures, the charger delivers maximum charging amperage to "wake up" any 12 volt battery quickly. When it reaches a maximum safe predetermined voltage, digital sensors automatically move into stage two of the charging process.

In stage two (Absorption mode), the charger elevates the voltage to a preset maximum value while monitoring the current. The charger maintains the maximum possible charge at a constant safe predetermined voltage. During stage two charging, the charging voltage remains constant, while the actual charging current is reduced to allow for the maximum proper internal chemical energy transfer. When the current decreases (tapers down) to a preset value, the charger enters stage three mode.

In stage three (Maintenance mode), the charger will vary current from none to a preset maximum current while maintaining the battery at full voltage charge. Voltage is automatically maintained and reduced to a predetermined level while current is adjusted for a safe, effective 100% charge (step-down regulation mode). This is ideal for topping off batteries that have been in storage. Maintenance mode **is not** a trickle mode. The charger will issue zero current if the battery accepts proper charge during the first two modes. This feature allows the charger to be connected indefinitely and it will not overcharge (or trickle charge) the battery. With automatic shut-off at 100% charge, you can trust the charger to never overcharge any battery.



NOTE: The current must be allowed to decrease down to the chargers pre-defined amperage in order for the charger to enter Maintenance mode. If your installation has a load on the battery in excess of this pre-defined amperage, the charger may stay in Absorption mode and never enter Maintenance mode.

With some Smart Chargers, if you connect a battery that contains less than the charger's pre-defined minimum voltage (typically 6 volts), the charger may assume there is a defect in the battery and it will not attempt to charge. Likewise if you turn the charger on without a battery connected, the charger may not output any voltage/current. This is a safety feature



which prevents output short circuits. They also have reverse hook-up protection to prevent short circuits.

Smart Chargers can compensate for temperature variations. At elevated temperatures, all voltages are lower. Likewise at colder temperatures, all voltages are higher. Normal operation of the charger assumes the battery and charger are in the same environment.

Always read and follow the manufacturer’s instructions for your battery charger.

19. Product Safety Sticker Outline

19.1. Fly Wire™ Trailer Safety Sticker Outline

Below is a self-explanatory list of the safety sticker included on the mobile trailer and Fly Wire™ tower. Please review the actual trailer and tower to familiarize yourself with the stickers pre-applied to the product.

Zippin Zone Master Sticker Outline 2012



2X



2X



2X



2X



2X



Pinch Point
Keep Clear
12X



4X



2X





3X



1X



1X



1X



1X



2X



11X



1X



1X



5X



19.2. Decelinator™ Safety Sticker Outline

Below is a self-explanatory list of the safety sticker included on the Decelinator™. Please review the actual Decelinator™ to familiarize yourself with the stickers pre-applied to the product.

Decelinator Sticker Outline 2012



1X



2X



1X



4X



2X



1X



4X



1X



1X



20.0 Limited Warranty

EXTREME ENGINEERING warrants to the first consumer purchaser that this product will be free from defective workmanship and materials. This warranty is nontransferable. Warranty is subject to the following conditions:

1. Extreme Engineering agrees that it will, at its option, either repair or replace a defective part or will, at its option, repair or replace the defective product, at no charge to the purchaser for labor for a period of ninety (90) days, at factory, from date of delivery, and at no charge to the purchaser for parts for a period of one (1) year from date of delivery (shipping and handling costs will apply). The consumer purchaser will have the following options when exchanging warranted parts: 1. The consumer purchaser will have to send the defective part or product back to Extreme Engineering's manufacturing plant. Extreme Engineering will determine if the part or product is defective. Extreme Engineering will send a replacement part free of charge if the part or product is found defective. or 2. The consumer purchaser will initially be charged for the warranted part or product. Once Extreme Engineering receives the defective part or product the consumer purchaser will be credited back if the part or product is found to be defective. Consumables are covered for 30 days (harnesses, zipline pulleys, zip cords, pulleys, carabiners, etc.). You may contact Extreme Engineering for additional details on consumable items. Extreme Engineering has a 90-day warranty on electronics, 30-day warranty on labor, 90-day warranty on parts. Decelinator™ systems are under warranty for the original purchaser(s) for one year (does not include zip cords).
2. This limited warranty is valid only when the product is installed, operated and maintained in accordance with the Extreme Engineering Owner's Manual. Any deviation from these recommended procedures must be approved in writing by Extreme Engineering.
3. This limited warranty does not apply to any part which has been subjected to misuse, abnormal service or handling or which has been altered or modified in design or construction.
4. This limited warranty does not apply to changes in the exterior appearance of the mobile Fly Wire™™. Custom painted products are not covered by Extreme Engineering's limited warranty.
6. Neither the sales personnel of the seller nor any other person is authorized to make any warranties other than those described herein or to extend the duration of any warranties beyond the time period described, on behalf of Extreme Engineering.
7. Do not book events until arrival of Extreme Engineering equipment. Extreme Engineering is not responsible for lost revenue from events booked prior to final delivery of equipment. Extreme Engineering is also not responsible for lost revenue due to unforeseen delays in shipment or delivery of Extreme Engineering equipment.



8. Customer agrees to use OEM parts when servicing an Extreme Engineering product. If the customer fails to abide by this term the product warranty will void and Extreme Engineering will not be responsible for failure of proper operation of an Extreme Engineering product.
9. By operating this product, the customer promises to operate and use any equipment in accordance with all owner's manuals service recommendations, service bulletins, recommendations and safety tips that the customer has received or may receive in the future in accordance with sound and accepted safety practices and according to applicable laws and regulations. The customer agrees that only trained and qualified staff or personnel shall supervise the use and operation of the equipment. The customer acknowledges that he/she has received, reviewed and understands Extreme Engineering's Owner's Manual and agrees to operate the equipment in accordance with the instructions provided therein.
10. (a) With the exception that this section shall in no event be construed to require indemnification by the customer to a greater extent than permitted under applicable law, the customer shall defend, indemnify, and hold harmless Extreme Engineering, including Extreme Engineering's officers, agents, employees, parents, and subsidiaries, and each of them, of and from any and all claims, demands, causes of action, damages, costs, expenses, actual attorneys' fees, losses or liabilities, in law or in equity, of every kind and nature whatsoever ("Claims") arising out of or related to the customer's operations, including but not limited to:
 - (i) Personal injury, including, but not limited to, bodily injury, emotional injury, loss of consortium or death to any person caused or alleged to be caused in whole or in part by any act or omission of Extreme Engineering, the customer or anyone directly or indirectly employed by the customer regardless of whether such personal injury or damage is caused by a party indemnified hereunder.
 - (ii) Penalties imposed on account of the violation of any law, ordinance, citation, rule, regulation, standard, ordinance, or statute, caused by the action or inaction of the customer or anyone directly or indirectly employed by the customer.
 - (iii) Any violations or infraction by the customer of any law, order, citation, rule, regulation, standard, ordinance, or statute in any way relating to the occupational health or safety of employees, including, but not limited to, the use of Extreme Engineering's or others' equipment, hoists, elevators or scaffolds.
 - (ix) Any failure or alleged failure to comply with the terms of this Customer Contract.

The customer, however, shall not be obligated under this Customer Contract to indemnify Extreme Engineering for Claims arising from the sole negligence or willful misconduct of Extreme Engineering or its agents, employees or independent contractors.

(b) Customer shall:



Version 1.47	Extreme Engineering® Fly Wire™ Owner's Manual	Page 144 of 148
--------------	--------------------------------------------------	-----------------

- (i) At the customer's own cost, expense, and risk, defend all Claims as defined above that may be brought or instituted by third persons, including, but not limited to, governmental agencies or employees of the customer, against Extreme Engineering or its agents or employees or any of them;
- (ii) Pay and satisfy any judgment or decree that may be rendered against Extreme Engineering or Owner or their agents or employees, or any of them, arising out of any such Claim;
- (1) Reimburse Extreme Engineering, its agents and employees for any and all legal expense incurred by any of them in connection herewith or in enforcing the indemnity granted in this Section (a). Nothing contained in this Customer Contract shall be deemed to obligate the customer to indemnify the indemnified parties against liability for damages or any other loss, damage or expense sustained, suffered or incurred on account of death or bodily injury to persons or damage to property caused by the sole negligence or willful misconduct of the indemnified parties.
- (2) Extreme Engineering is not responsible for acts of God.

All of the terms and conditions of this operating manual shall become binding when used by an authorized representative of the customer.

- 7. THE WARRANTIES DESCRIBED HERE SHALL BE THE SOLE AND EXCLUSIVE WARRANTIES GRANTED BY EXTREME ENGINEERING AND SHALL BE THE SOLE AND EXCLUSIVE REMEDY AVAILABLE TO THE ORIGINAL PURCHASER. Correction of defects, in the manner and for the period of time described here, shall constitute complete fulfillment of all liabilities and responsibilities, whether based on contract, negligence, strict liability or otherwise. In no event shall Extreme Engineering be liable, or in any way responsible, for damages or defects in the product which were caused by repairs performed by anyone other than an authorized servicer.
- 8. Extreme Engineering shall not be liable, or in any way responsible, for incidental or consequential economic or property damage.
- 9. Technical support is available to the original purchaser up to one year from the purchase date of an Extreme Engineering product. Technical support outside of the one year warranty period is available for a fee.

21.0. Warranty Claim

In the event of a warranty claim, please fill out the warranty claim page located on the last page of this manual. You may download a copy from Extreme Engineering's technical support page at www.extremeengineering.com. You may also call Extreme Engineering for a copy of the warranty claim form. The warranty claim form must be filled out and sent with the defective product. You may also fax a copy to Extreme Engineering's Customer Service Department at 916-663-9249. You may contact customer service at 916-663-1560.



Warranty claim service must be performed and approved by the Extreme Engineering Customer Service Department. Warranty replacement hardware systems and components or parts will be free of charge. Shipping and handling costs on defective items returned to Extreme Engineering are paid by the consumer purchaser. Labor cost to repair or replace will be limited to the amount of the original purchase price of the systems and components. The replaced warranty products or parts become the property of Extreme Engineering and must be returned to the Extreme Engineering Customer Service Department freight prepaid, unless prior arrangements have been made.

22.0.Replacement Parts

Purchase your replacement parts through our customer support center at:
(916) 663-1560

or visit our online store at:

www.extremeengineering.com/store/

Always make sure that your Extreme Engineering products are running at optimal performance.

23.0.Technical Support

If you require technical support and your product is still under warranty, contact customer service to schedule free technical support on your product. Technical support will respond within 24 hours once a claim is placed.

You may call customer service at:

916-663-1560

or

visit our technical page at:

<http://www.extremeengineering.com/about-us/technical-support/>

Copyright © Extreme Engineering. This manual is not to be copied, modified or redistributed without written approval by Extreme Engineering.





Warranty Claim Form

Company Name:			Date:
Customer Name:			
Address:			
City:	State:	Zip:	Country:
Phone:	Fax:		
Email:			
Product Name (Part Number):		Purchase Date:	
Sales Order Number:			
Detailed Description of Current Issue(s):			



THIS PAGE IS LEFT BLANK.

© Extreme Engineering

